

Artículo 5: Vehículos homologados

Lista de vehículos homologados para competencias de velocidad de Gran Turismo							
Para clase GT1 únicamente							
Marca	Modelo	Tipo de motorización		Periodo de fabricación	Suspensión delantera	Suspensión trasera	Disposición
Alfa-Romeo	2600 Sprint	6 en línea		1961 - 1968	Doble Parrilla	Puente rígido	MDL - TT
Alfa-Romeo	GTV6	V6		1980 - 1987	Doble Parrilla	Puente de Dion	MDL - TT
Alfa-Romeo	Montreal	V8		1970 - 1977	Doble Parrilla	Puente rígido	MDL - TT
BMW	CS/CSL E9	6 en línea		1968 - 1975	MacPherson	Brazo arrastrado	MDL - TT
BMW	Serie 3 E21	6 en línea		1975 - 1983	MacPherson	Brazo arrastrado	MDL - TT
BMW	Serie 3 E30 (2 puertas)	6 en línea		1982 - 1991	MacPherson	Brazo arrastrado	MDL - TT
BMW	Serie 6 E24	6 en línea		1976 - 1989	MacPherson	Brazo arrastrado	MDL - TT
Chevrolet	Camaro	6 en línea	V8	1966 - 1969	Doble Parrilla	Puente rígido	MDL - TT
Chevrolet	Camaro II	6 en línea	V8	1970 - 1981	Doble Parrilla	Puente rígido	MDL - TT
Chevrolet	Camaro III	6 en línea	V6 V8	1982 - 1992	Doble Parrilla	Puente rígido	MDL - TT
Datsun	240Z-260Z-280Z (Nissan S30)	6 en línea		1969 - 1978	MacPherson	Chapman	MDL - TT
Datsun	280ZX (Nissan S130)	6 en línea		1978 - 1983	MacPherson	Brazo arrastrado	MDL - TT
Ferrari	308	V8		1977 - 1985	Doble Parrilla	Doble Parrilla	MTCT - TT
Ferrari	Mondial	V8		1980 - 1989	Doble Parrilla	Doble Parrilla	MTCT - TT
Ferrari-Dino	246	V6		1969 - 1974	Doble Parrilla	Doble Parrilla	MTCT - TT
Ferrari-Dino	308 GT4	V8		1973 - 1980	Doble Parrilla	Doble Parrilla	MTCT - TT
Fiat	Dino Coupe	V6		1967 - 1969	Doble Parrilla	Puente rígido	MDL - TT
Fiat	Dino Coupe 2400	V6		1969 - 1973	Doble Parrilla	Brazo arrastrado	MDL - TT
Fiat	Dino Spider	V6		1966 - 1969	Doble Parrilla	Puente rígido	MDL - TT
Fiat	Dino Spider 2400	V6		1969 - 1973	Doble Parrilla	Brazo arrastrado	MDL - TT
Ford	Capri MkI	V6		1969 - 1974	MacPherson	Puente rígido	MDL - TT
Ford	Capri MkII	V6		1974 - 1978	MacPherson	Puente rígido	MDL - TT
Ford	Capri MkIII	V6		1978 - 1986	MacPherson	Puente rígido	MDL - TT
Ford	Mustang	6 en línea	V8	1964 - 1973	Doble Parrilla	Puente rígido	MDL - TT
Ford	Mustang II	V6	V8	1974 - 1978	Doble Parrilla	Puente rígido	MDL - TT

Ford	Mustang III	6 en línea	V6	V8	1979 - 1993	MacPherson	Puente rígido	MDL - TT
Ford	Sierra (3 puertas)	V6			1983 - 1991	MacPherson	Brazo arrastrado	MDL - TT
IKA-Renault	Torino Coupe	6 en línea			1966 - 1981	Doble Parrilla	Puente rígido	MDL - TT
Maserati	Merak	V6			1972 - 1982	Doble Parrilla	Doble Parrilla	MTCL - TT
Mercedes-Benz	SEC W126	V8			1981 - 1991	Doble Parrilla	Brazo arrastrado	MDL - TT
Mercedes-Benz	SLC W107	6 en línea	V8		1971 - 1981	Doble Parrilla	Brazo arrastrado	MDL - TT
Mercedes-Benz	190 W201	6 en línea			1982 - 1993	MacPherson	Doble Parrilla	MDL - TT
MG	B GT	V8			1965 - 1980	Doble Parrilla	Puente rígido	MDL - TT
MG	C	6 en línea			1967 - 1969	Doble Parrilla	Puente rígido	MDL - TT
Peugeot	504 Coupé	V6			1969 - 1983	MacPherson	Brazo arrastrado	MDL - TT
Porsche	914	Boxer 6			1969 - 1972	MacPherson	Brazo arrastrado	MTCL - TT
Porsche	928	V8			1978 - 1995	Doble Parrilla	Doble Parrilla	MDL - TT
Porsche	911/901	Boxer 6			1963 - 1973	MacPherson	Brazo arrastrado	MTL - TT
Porsche	911/930	Boxer 6			1974 - 1988	MacPherson	Brazo arrastrado	MTL - TT
Toyota	Celica Supra MkI	6 en línea			1979 - 1981	MacPherson	Puente rígido	MDL - TT
Toyota	Celica Supra MkII	6 en línea			1982 - 1986	MacPherson	Puente rígido	MDL - TT
Volvo	262	V6			1975 - 1984	MacPherson	Puente rígido	MDL - TT

MDCL: motor delantero-central longitudinal.

MDL: motor delantero longitudinal.

MDT: motor delantero transversal.

MTCL: motor trasero-central longitudinal.

MTCT: motor trasero-central transversal.

MTL: motor trasero longitudinal.

TD: tracción delantera.

TT: tracción trasera.

Lista de vehículos homologados para competencias de velocidad de Gran Turismo
Para clases GT1, GT2 y GT3

Marca	Modelo	Tipo de motorización	Periodo de fabricación	Suspensión delantera	Suspensión trasera	Disposición
Alfa-Romeo	Alfasud Sprint	Boxer 4	1976 - 1989	MacPherson	Eje rígido	MDL - TD
Alfa-Romeo	Alfasud ti	Boxer 4	1973 - 1984	MacPherson	Eje rígido	MDL - TD
Alfa-Romeo	Alfetta GT / GTV (4 cilindros)	4 en línea	1974 - 1986	Doble Parrilla	Puente de Dion	MDL - TT
Alfa-Romeo	Duetto Spider	4 en línea	1966 - 1969	Doble Parrilla	Puente rígido	MDL - TT
Alfa-Romeo	Giulia Spider 101	4 en línea	1962 - 1965	Doble Parrilla	Puente rígido	MDL - TT
Alfa-Romeo	Giulia Sprint 101	4 en línea	1962 - 1964	Doble Parrilla	Puente rígido	MDL - TT
Alfa-Romeo	Giulia Sprint 105	4 en línea	1963 - 1976	Doble Parrilla	Puente rígido	MDL - TT
Alfa-Romeo	Giulietta Spider 101	4 en línea	1955 - 1962	Doble Parrilla	Puente rígido	MDL - TT
Alfa-Romeo	Giulietta Sprint 101	4 en línea	1954 - 1965	Doble Parrilla	Puente rígido	MDL - TT
Alfa-Romeo	Giulietta 116	4 en línea	1977 - 1985	Doble Parrilla	Puente de Dion	MDL - TT
Alfa-Romeo	Spider Veloce	4 en línea	1970 - 1994	Doble Parrilla	Puente rígido	MDL - TT
Bertone	X1/9	4 en línea	1982 - 1989	MacPherson	Chapman	MTCT - TT
BMW	1602	4 en línea	1966 - 1975	MacPherson	Brazo arrastrado	MDL - TT
BMW	2002	4 en línea	1968 - 1976	MacPherson	Brazo arrastrado	MDL - TT
BMW	Serie 3 E21 (4 cilindros)	4 en línea	1975 - 1983	MacPherson	Brazo arrastrado	MDL - TT
BMW	Serie 3 E30 (4 cil. 2 p.)	4 en línea	1982 - 1991	MacPherson	Brazo arrastrado	MDL - TT
Fiat	124 Abarth Rally	4 en línea	1972 - 1975	Doble Parrilla	Chapman	MDL - TT
Fiat	124 Sport Coupé	4 en línea	1967 - 1975	Doble Parrilla	Puente rígido	MDL - TT
Fiat	124 Sport Spider	4 en línea	1966 - 1985	Doble Parrilla	Puente rígido	MDL - TT
Fiat	125 Sport	4 en línea	1972 - 1978	Doble Parrilla	Puente rígido	MDL - TT
Fiat	128 Sport Coupé	4 en línea	1971 - 1979	MacPherson	Chapman	MDT - TD
Fiat	131 Abarth	4 en línea	1976 - 1978	MacPherson	Chapman	MDL - TT
Fiat	131 Racing	4 en línea	1978 - 1981	MacPherson	Puente rígido	MDL - TT
Fiat	1500 Coupe	4 en línea	1966 - 1970	Doble Parrilla	Puente rígido	MDL - TT
Fiat	1600 Sport	4 en línea	1970 - 1972	Doble Parrilla	Puente rígido	MDL - TT
Fiat	X1/9	4 en línea	1972 - 1989	MacPherson	Chapman	MTCT - TT
Ford	Capri MkI	4 en línea	1969 - 1974	MacPherson	Puente rígido	MDL - TT

Ford	Capri MkII	4 en línea	1974 - 1978	MacPherson	Puente rígido	MDL - TT
Ford	Capri MkIII	4 en línea	1978 - 1986	MacPherson	Puente rígido	MDL - TT
Ford	Cortina Mark I (2 puertas)	4 en línea	1962 - 1966	MacPherson	Puente rígido	MDL - TT
Ford	Escort Mark I (2 puertas)	4 en línea	1968 - 1975	MacPherson	Puente rígido	MDL - TT
Ford	Escort Mark II (2 puertas)	4 en línea	1975 - 1980	MacPherson	Puente rígido	MDL - TT
Ford	Sierra (3 puertas)	4 en línea	1983 - 1991	MacPherson	Brazo arrastrado	MDL - TT
Lancia	Beta Coupé	4 en línea	1972 - 1984	MacPherson	Chapman	MDT - TD
Lancia	Beta HPE	4 en línea	1972 - 1984	MacPherson	Chapman	MDT - TD
Lancia	Beta Montecarlo	4 en línea	1975 - 1978	MacPherson	Chapman	MTCT - TT
Lancia	Fulvia Coupé	V4	1965 - 1976	Doble Parrilla	Eje rígido	MDL - TD
Lancia	Fulvia Sport	V4	1965 - 1976	Doble Parrilla	Eje rígido	MDL - TD
Lancia	Montecarlo	4 en línea	1980 - 1981	MacPherson	Chapman	MTCT - TT
Mercedes-Benz	190 W201 (4 cilindros)	4 en línea	1982 - 1993	MacPherson	Doble Parrilla	MDL - TT
MG	B	4 en línea	1962 - 1980	Doble Parrilla	Puente rígido	MDL - TT
MG	B GT (4 cilindros)	4 en línea	1965 - 1980	Doble Parrilla	Puente rígido	MDL - TT
Mitsubishi	Sapporo	4 en línea	1976 - 1984	MacPherson	Puente rígido	MDL - TT
Peugeot	205 (3 puertas)	4 en línea	1983 - 1998	MacPherson	Brazo arrastrado	MDT - TD
Peugeot	504 Coupé (4 cilindros)	4 en línea	1969 - 1983	MacPherson	Brazo arrastrado	MDL - TT
Porsche	912	Boxer 4	1965 - 1969	MacPherson	Brazo arrastrado	MTL - TT
Porsche	912E	Boxer 4	1976 - 1976	MacPherson	Brazo arrastrado	MTL - TT
Porsche	924	4 en línea	1976 - 1985	MacPherson	Brazo arrastrado	MDL - TT
Renault	5 primera serie (3 puertas)	4 en línea	1972 - 1984	Doble Parrilla	Brazo arrastrado	MDCL - TD
Renault	Fuego	4 en línea	1980 - 1992	Doble Parrilla	Eje rígido	MDL - TD
Toyota	Célica A20/35	4 en línea	1970 - 1977	MacPherson	Puente rígido	MDL - TT
Toyota	Célica A40	4 en línea	1978 - 1981	MacPherson	Puente rígido	MDL - TT
Volkswagen	Golf MkI (3 puertas)	4 en línea	1974 - 1984	MacPherson	Eje semi-independiente	MDT - TD
Volkswagen	Golf MkII (3 puertas)	4 en línea	1983 - 1992	MacPherson	Eje semi-independiente	MDT - TD
Volkswagen	Passat B1 (2 ó 3 puertas)	4 en línea	1973 - 1988	MacPherson	Eje rígido	MDL - TD
Volkswagen	Scirocco MkI	4 en línea	1974 - 1982	MacPherson	Eje semi-independiente	MDT - TD
Volkswagen	Scirocco MkII	4 en línea	1982 - 1992	MacPherson	Eje semi-independiente	MDT - TD
Volkswagen-Porsche	914 (4 cilindros)	Boxer 4	1969 - 1976	MacPherson	Brazo arrastrado	MTCL - TT
Volvo	242	4 en línea	1974 - 1984	MacPherson	Puente rígido	MDL - TT

FIGURINES VEHICULOS EXCLUSIVOS PARA GT1

Alfa-Romeo 2600 Sprint (1961 - 1968)

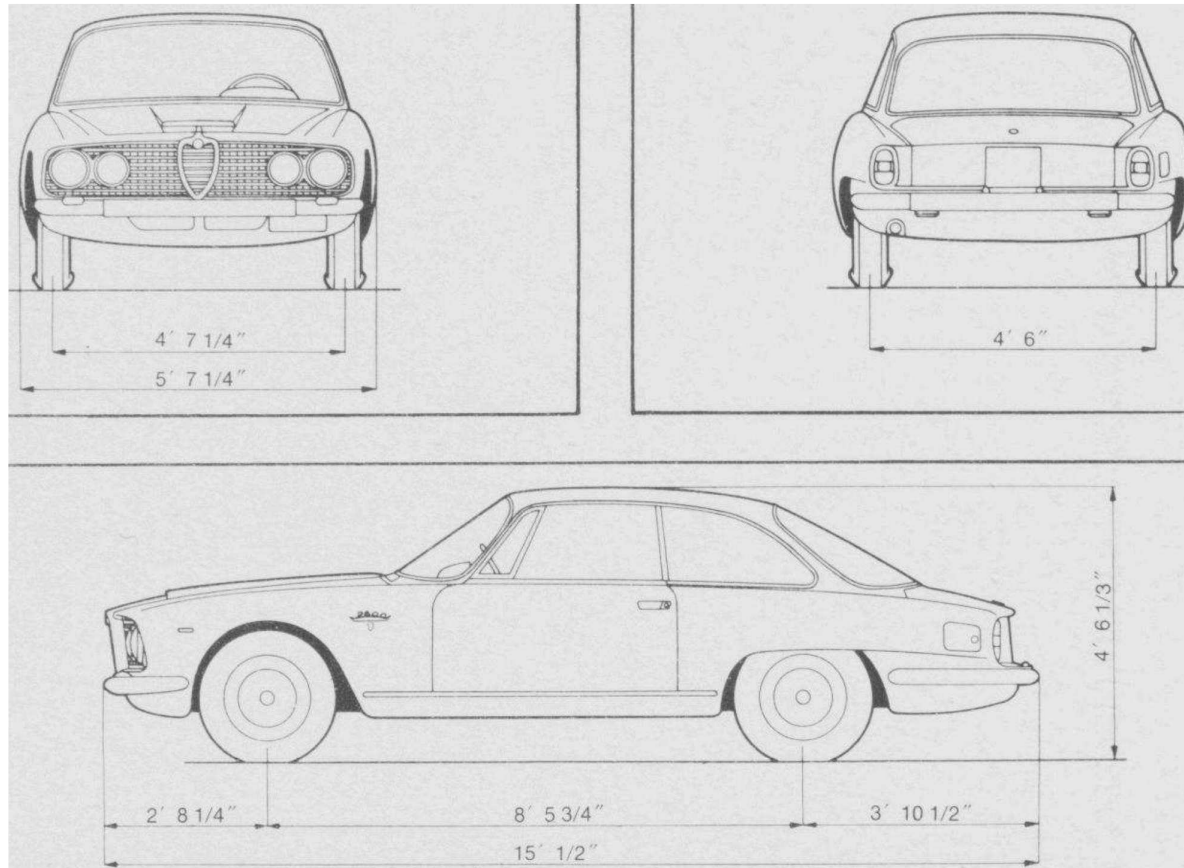

Alfa-Romeo GTV6 (1980 - 1987)

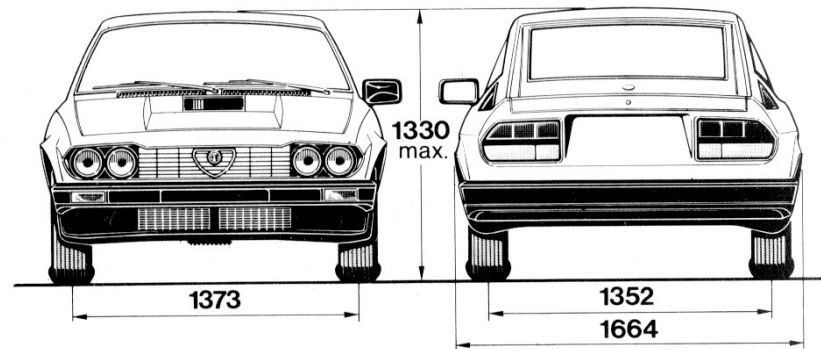
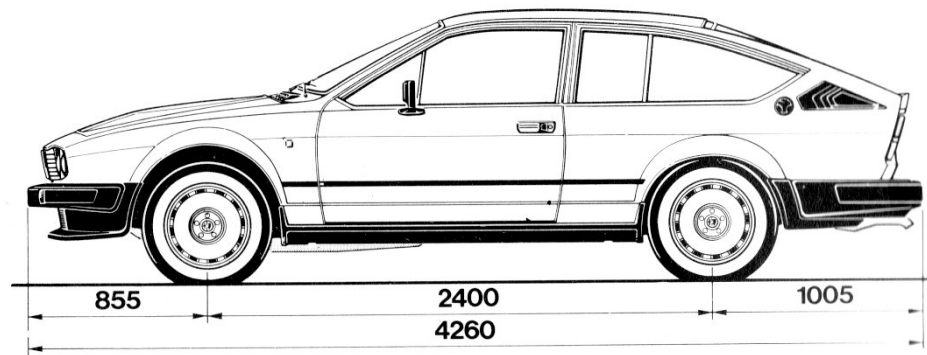

Alfa-Romeo Montreal (1970 - 1977)

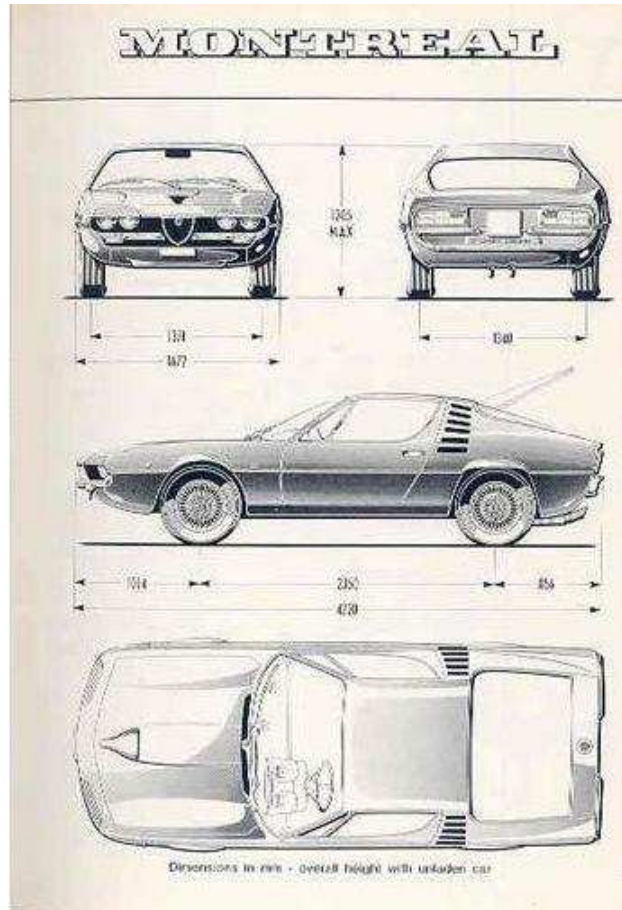

BMW CS/CSL E9 (1968 - 1975)

BMW 3.0 CSL

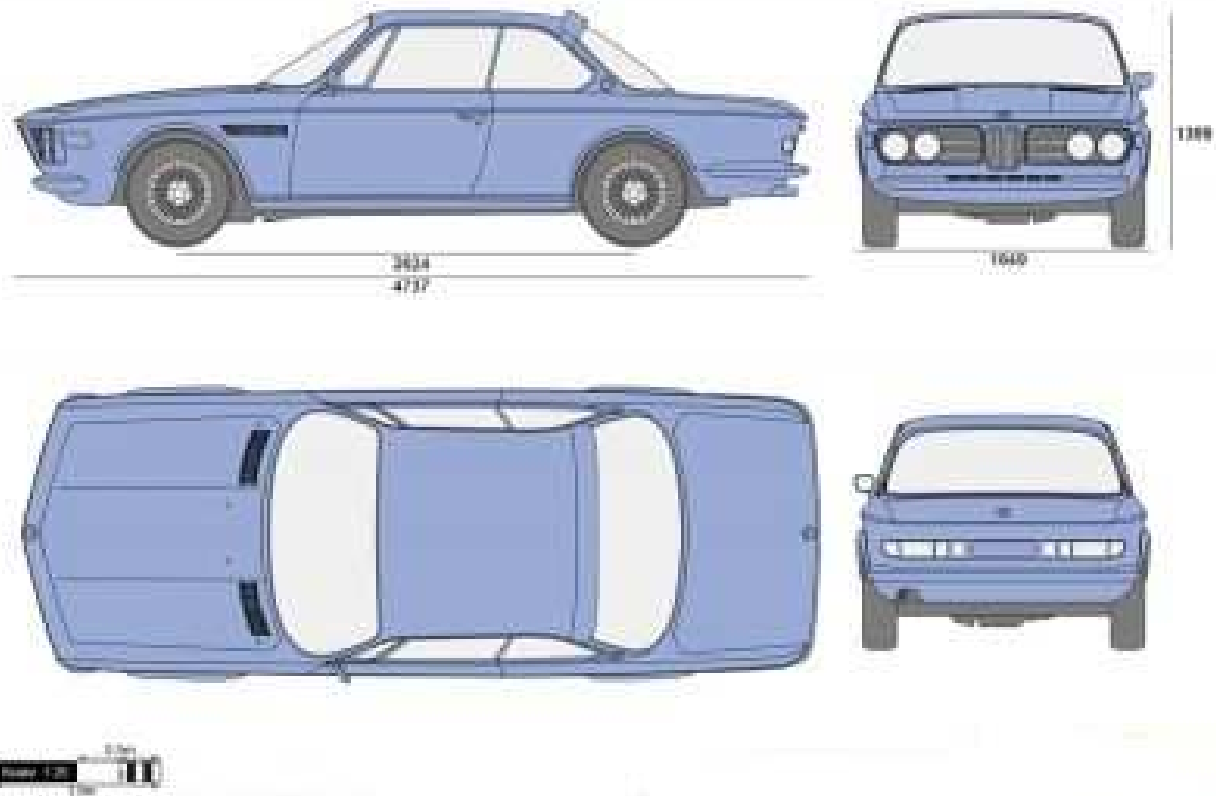

BMW Serie 3 E21 (1975 - 1983)

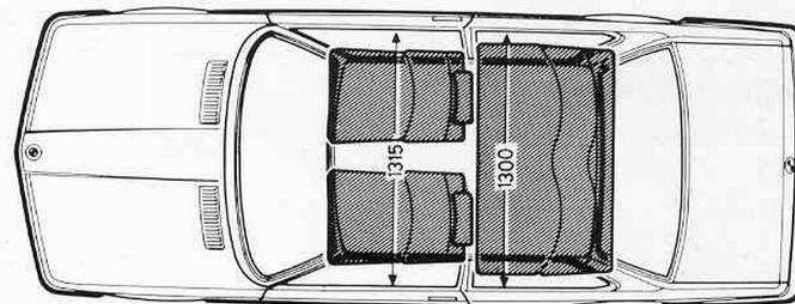
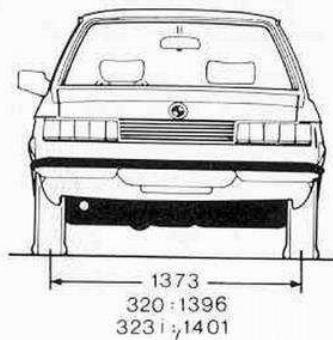
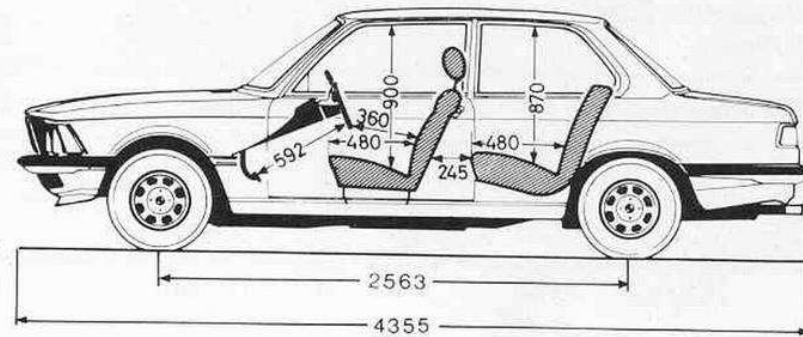
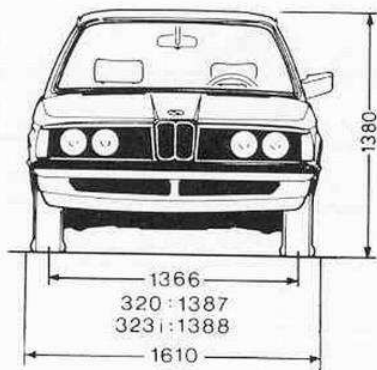

BMW serie 3 E30 (2 puertas) (1982 - 1991)

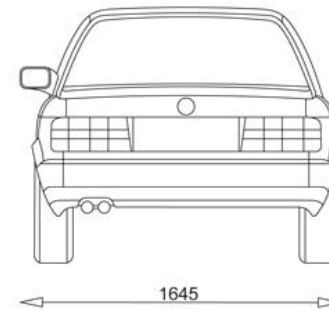
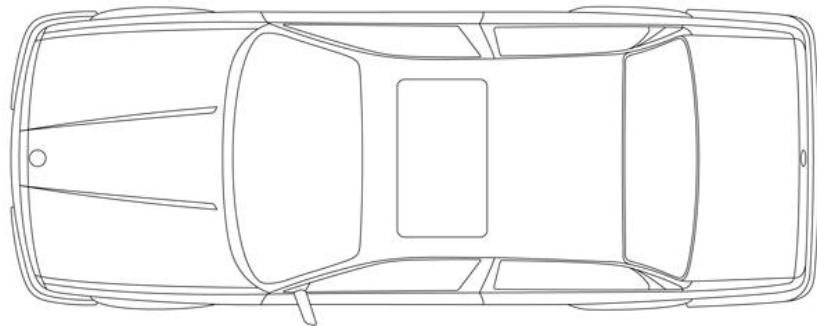
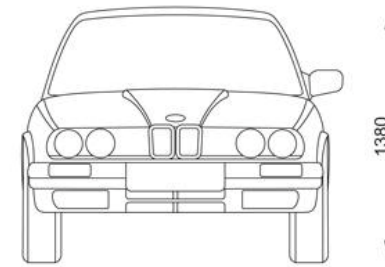
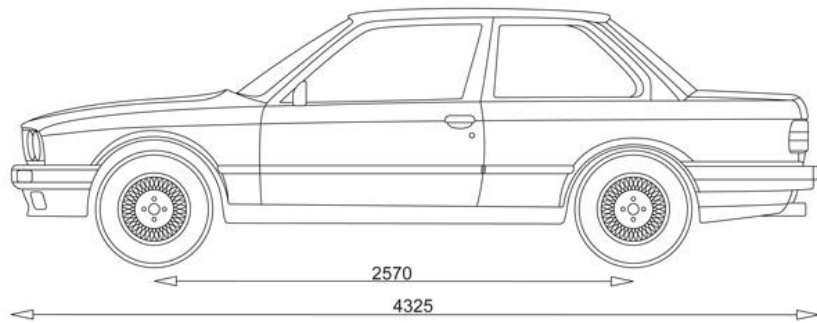

BMW Serie 6 E24 (1976 - 1989)

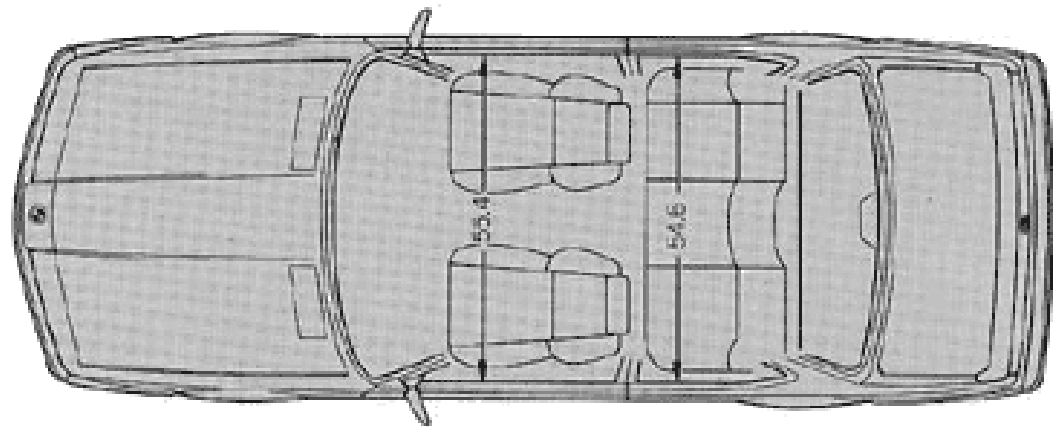
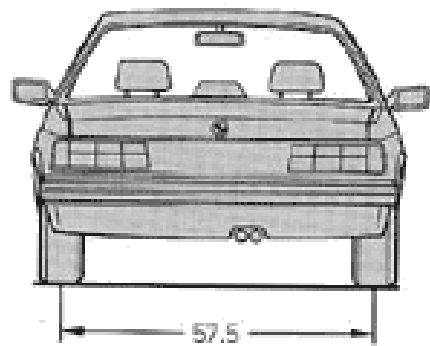
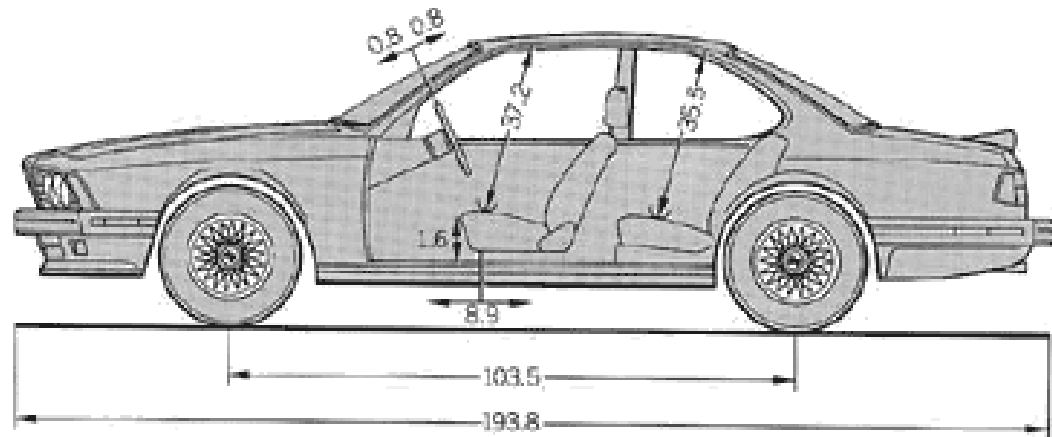
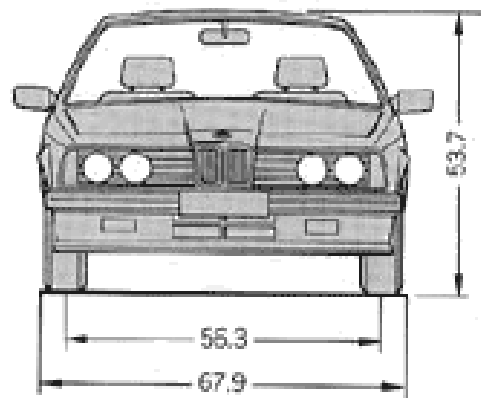

Chevrolet Camaro (1966 - 1969)

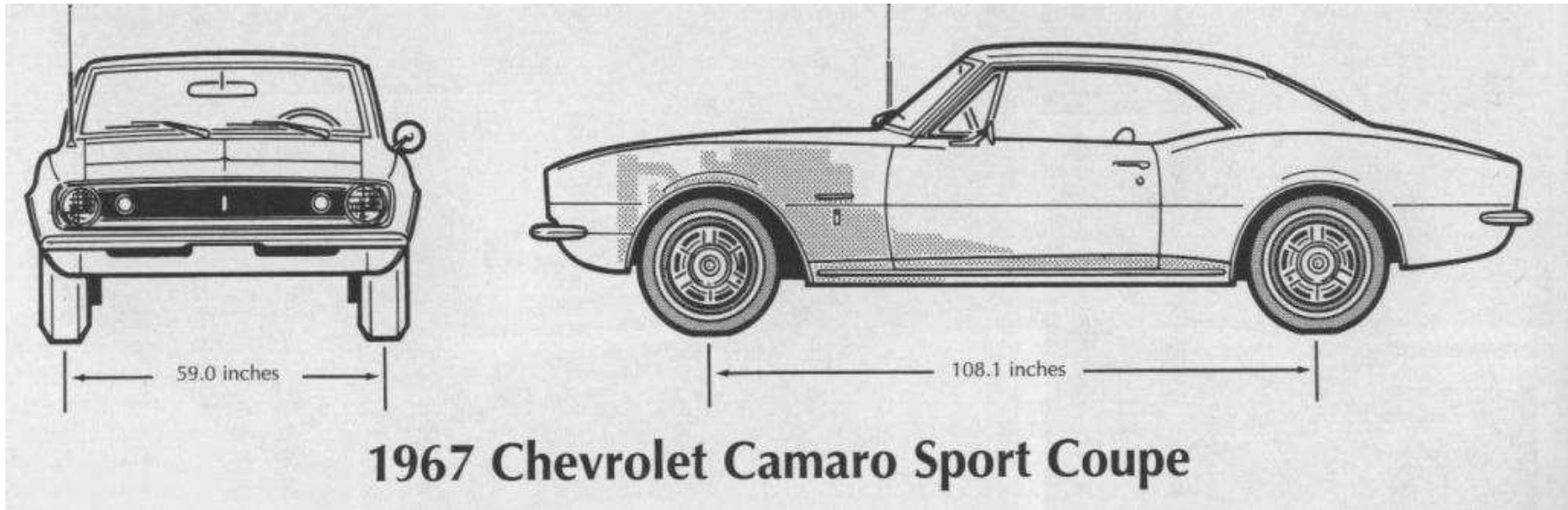

Chevrolet Camaro II (1970 - 1981)

Chevrolet Camaro III (1982 - 1992)

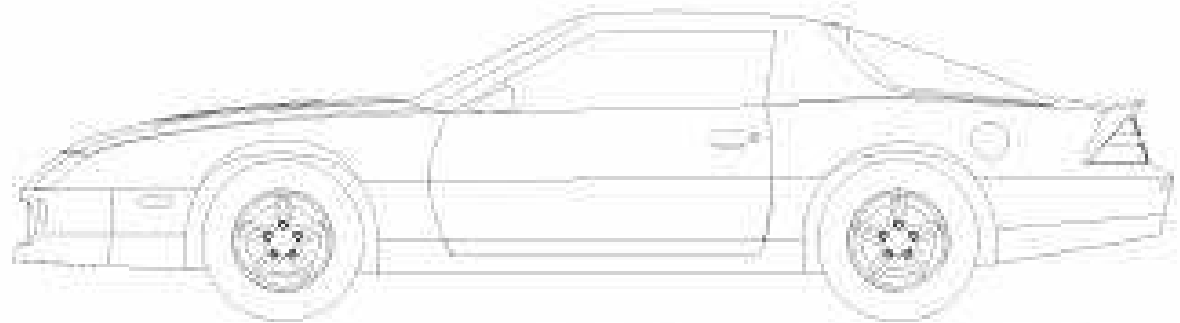
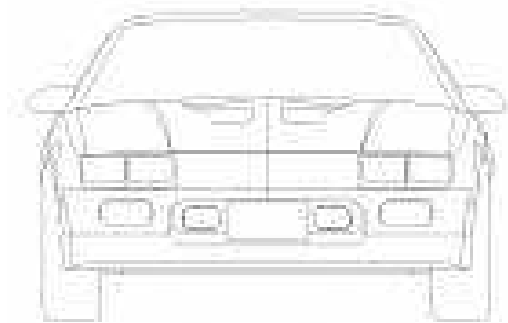
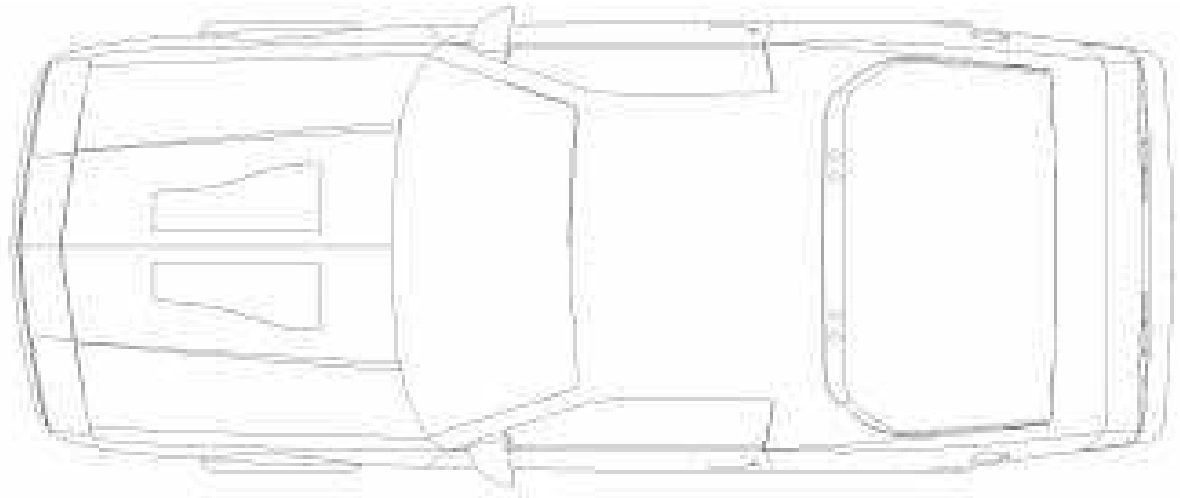
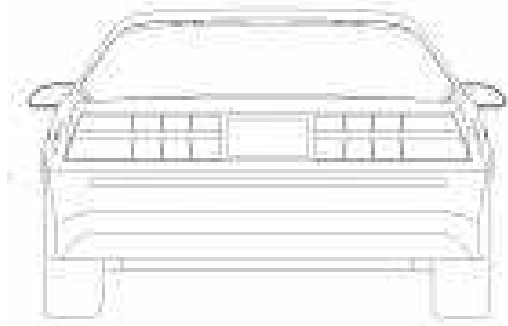

Datsun 240Z-260Z-280Z (Nissan S30) (1969 - 1978)

Datsun 280ZX (Nissan S130) (1978 - 1983)

Alle Angaben in mm

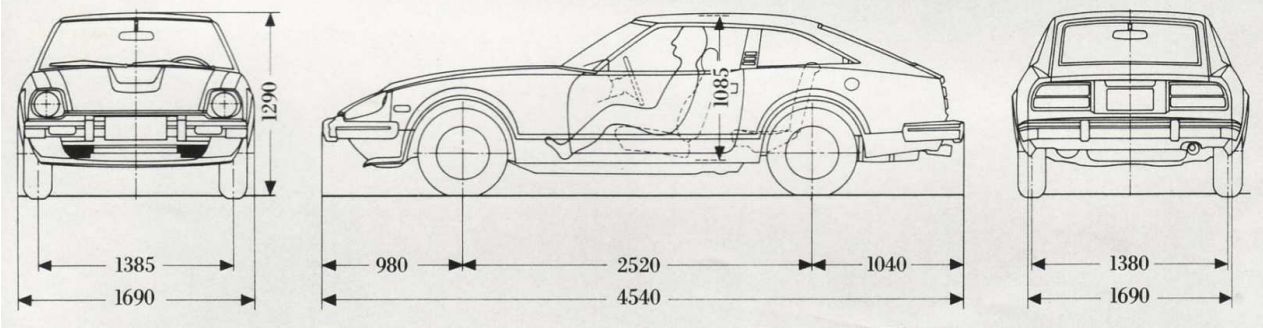

Ferrari 308 (1977 - 1985)

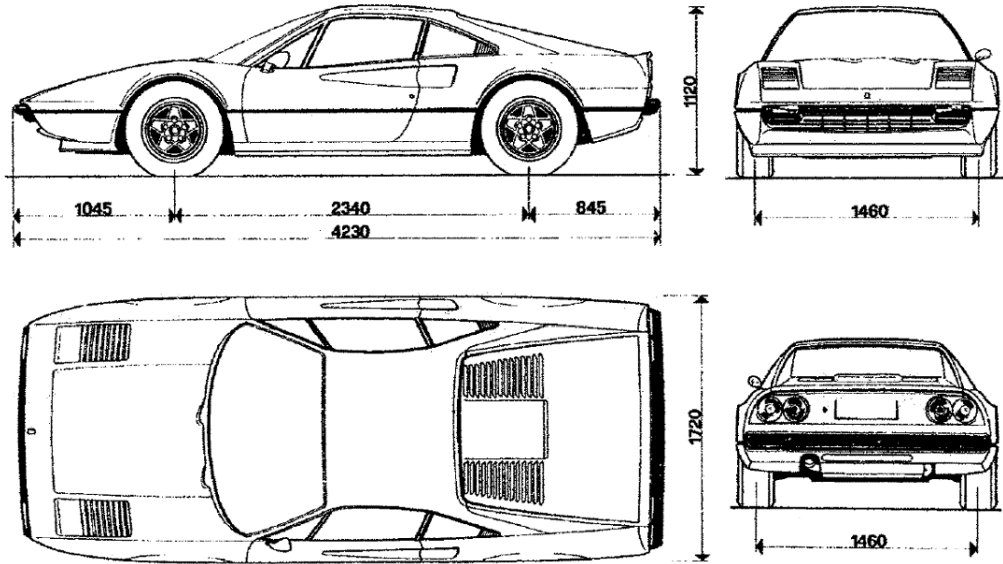

Ferrari Mondial (1980 - 1989)

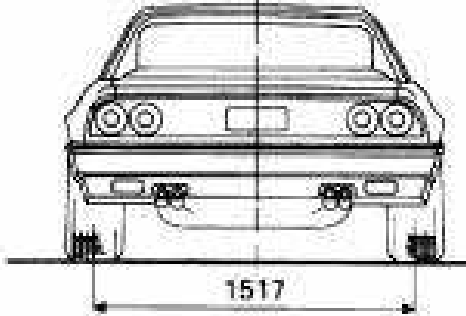
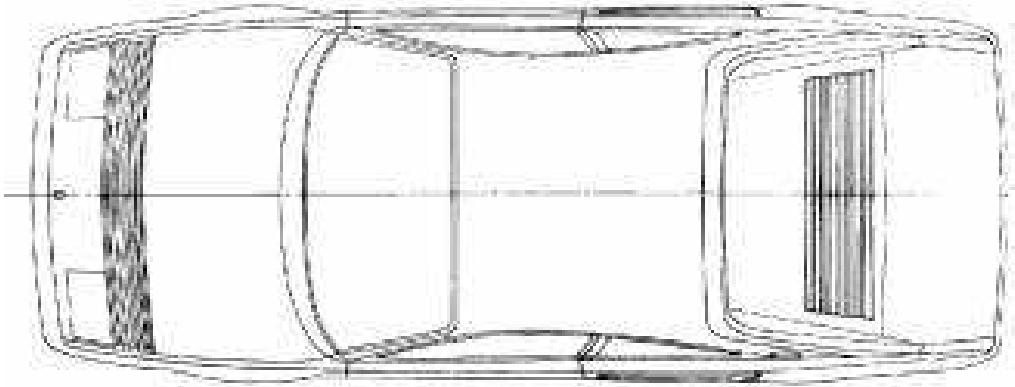
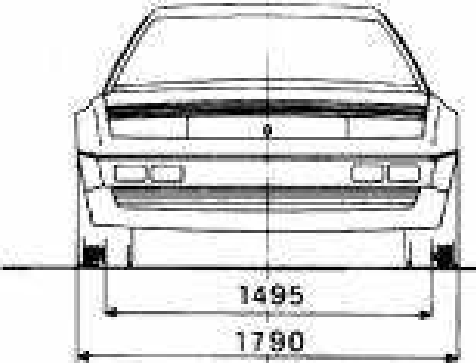
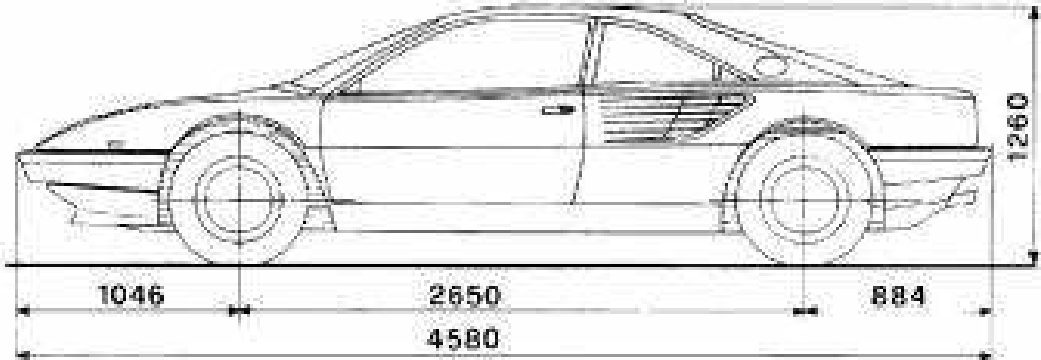

Ferrari-Dino 246 (1969 - 1974)

Ferrari Dino 246 GT (1969)

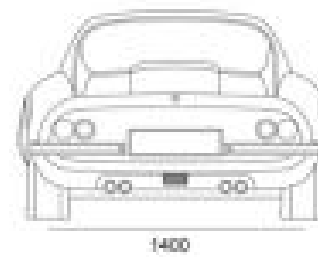
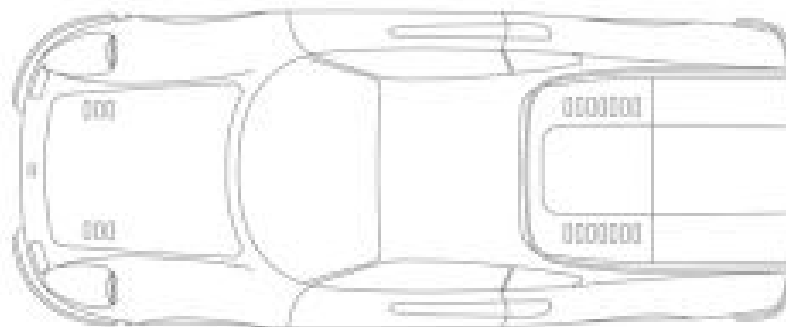
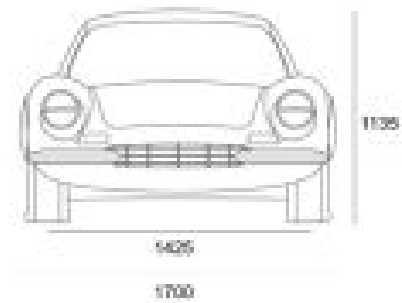
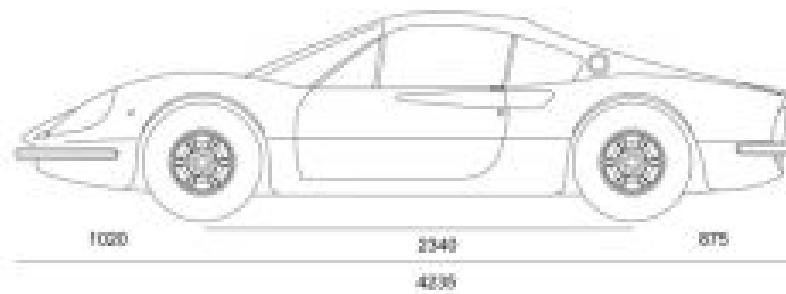

Ferrari-Dino 308 GT4 (1973 - 1980)

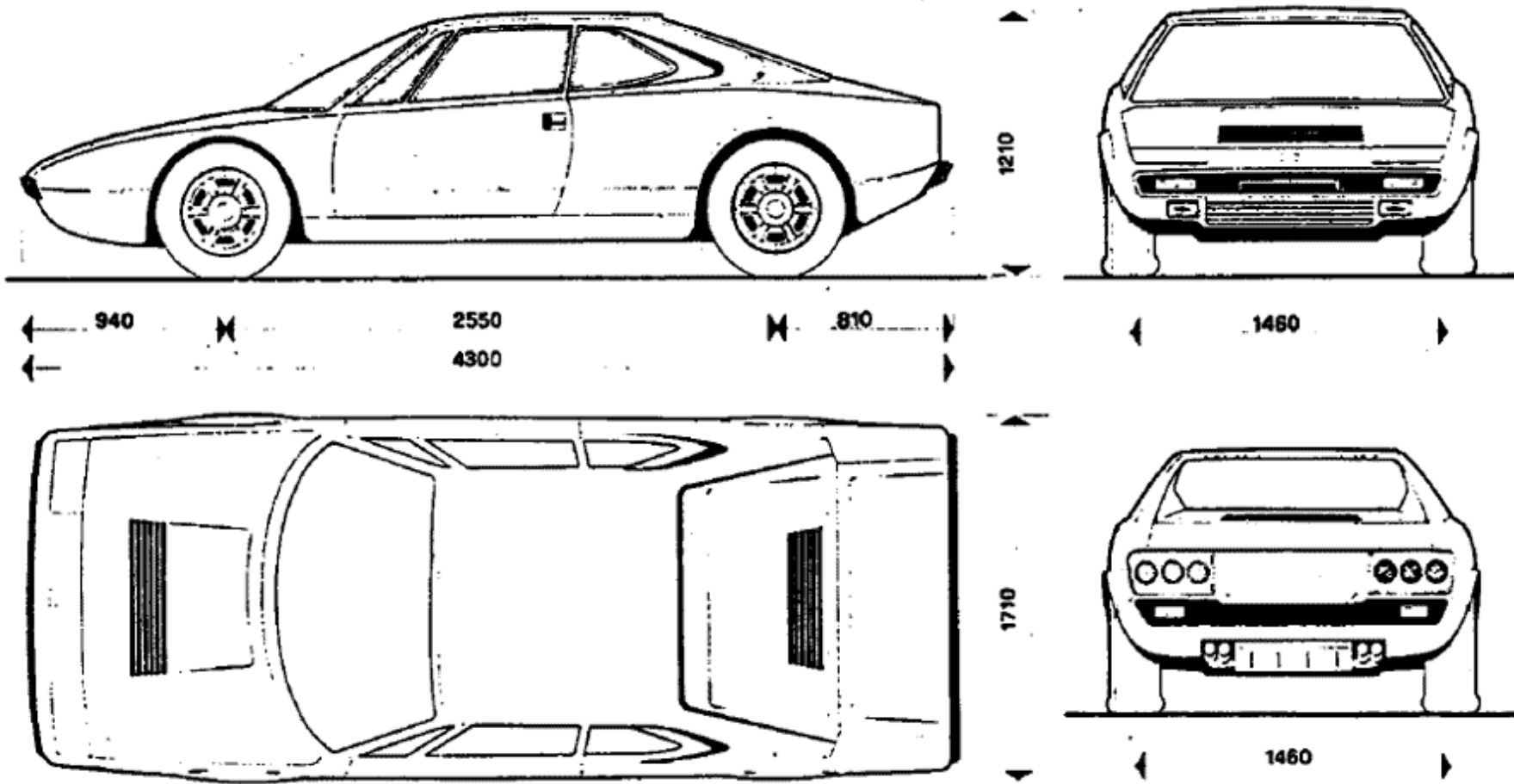

Fiat Dino Coupe (1967 - 1969)

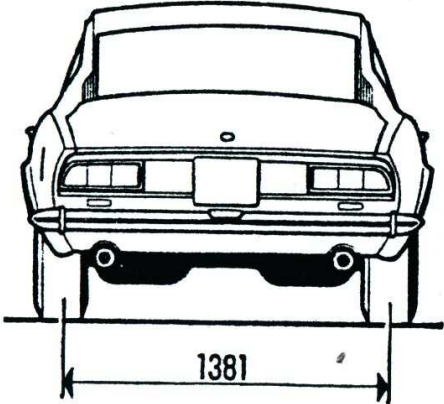
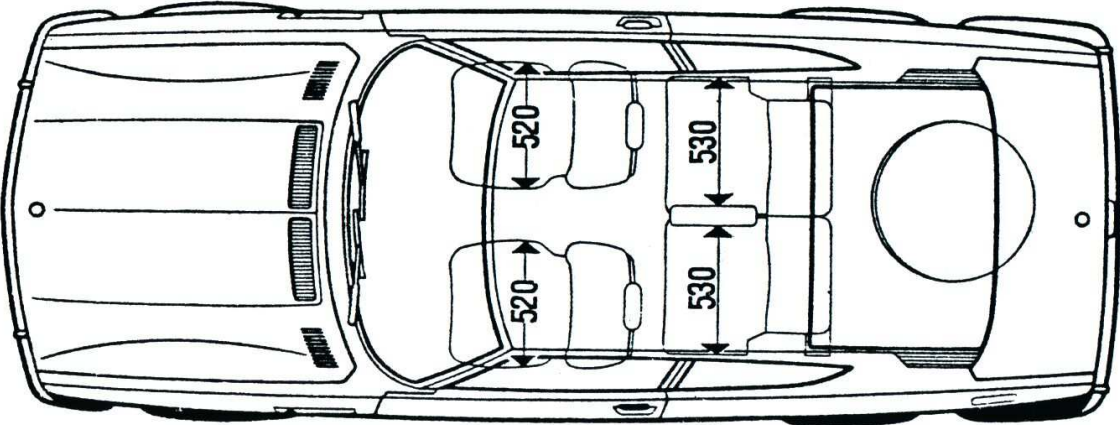
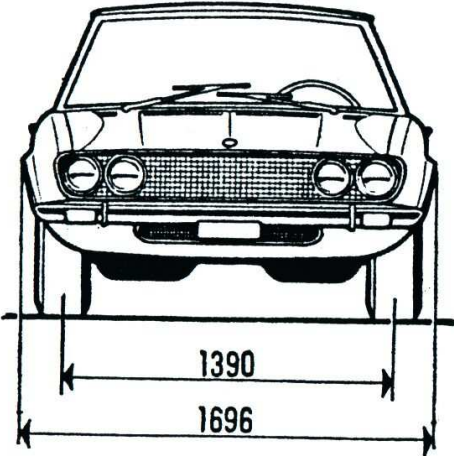
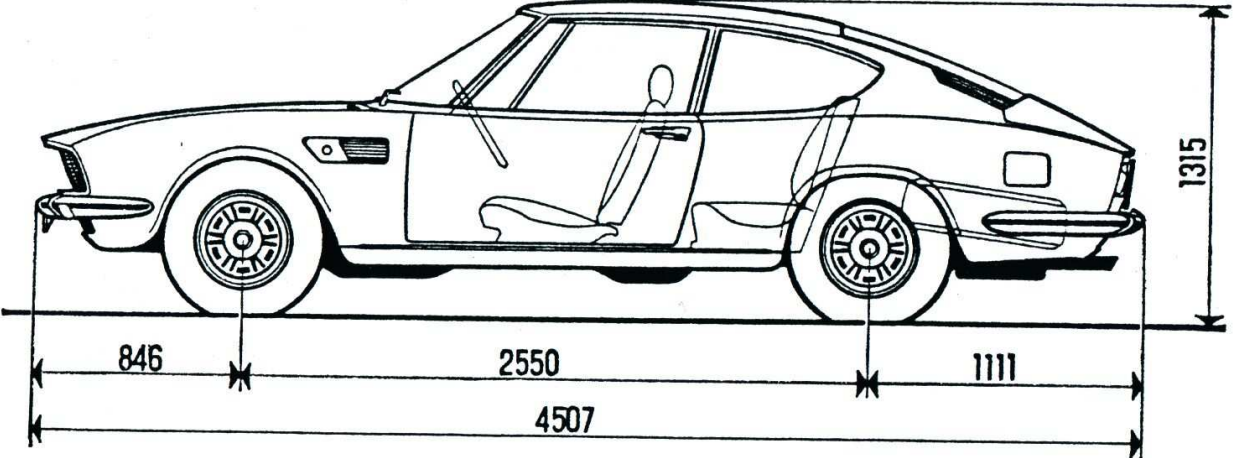

Fiat Dino Coupe 2400 (1969 - 1973)

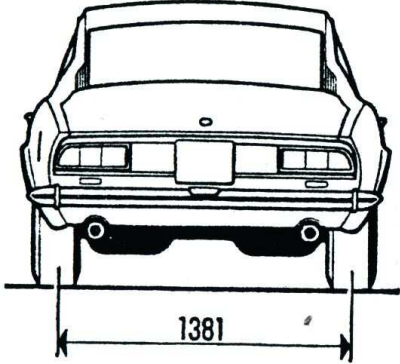
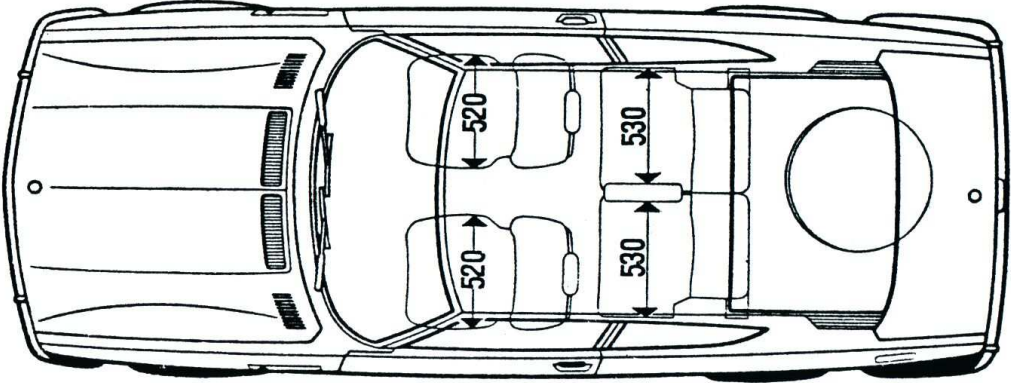
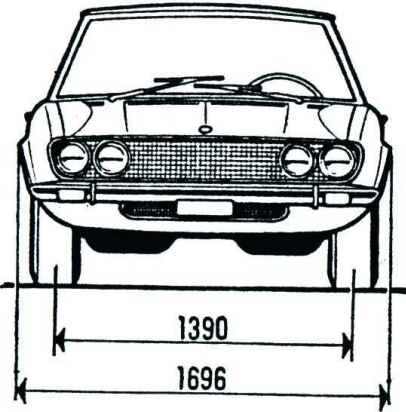
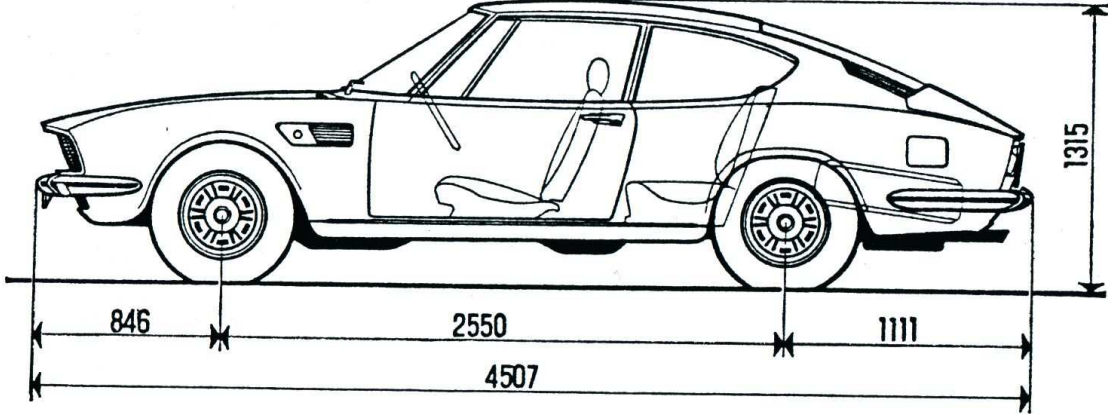

Fiat Dino Spider (1966 - 1969)

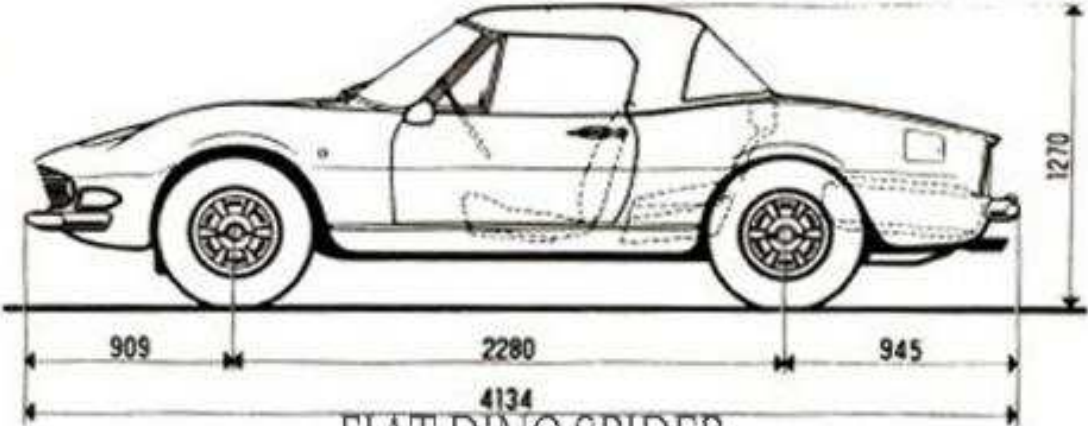

FIAT DINO SPIDER

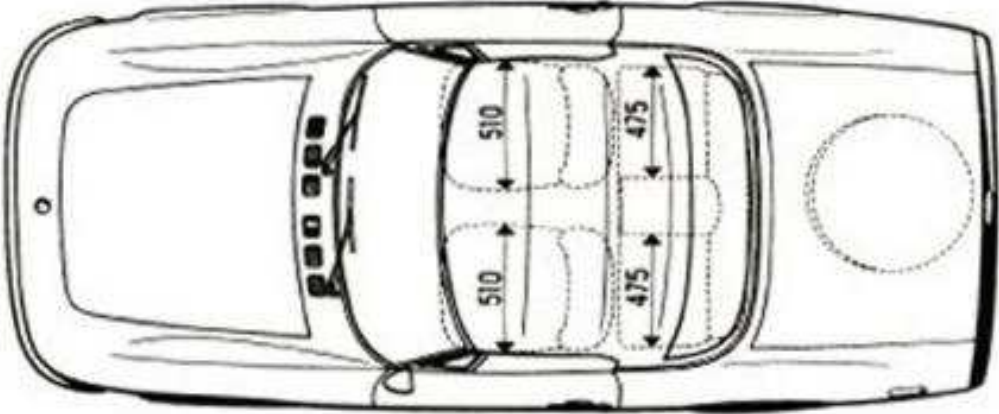

Fiat Dino Spider 2400 (1969 - 1973)

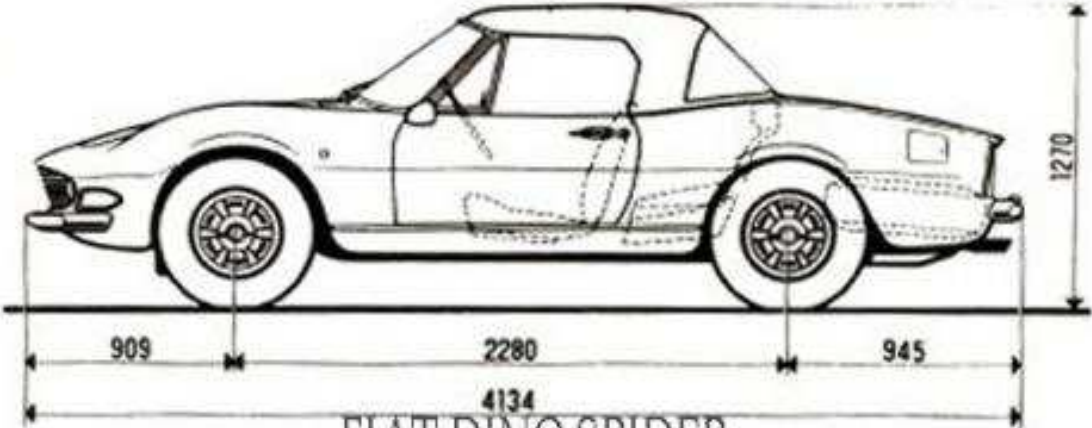

FIAT DINO SPIDER

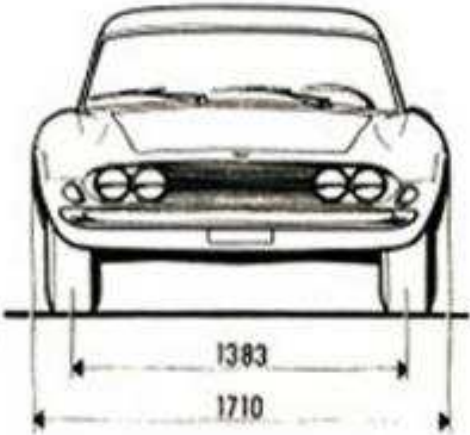
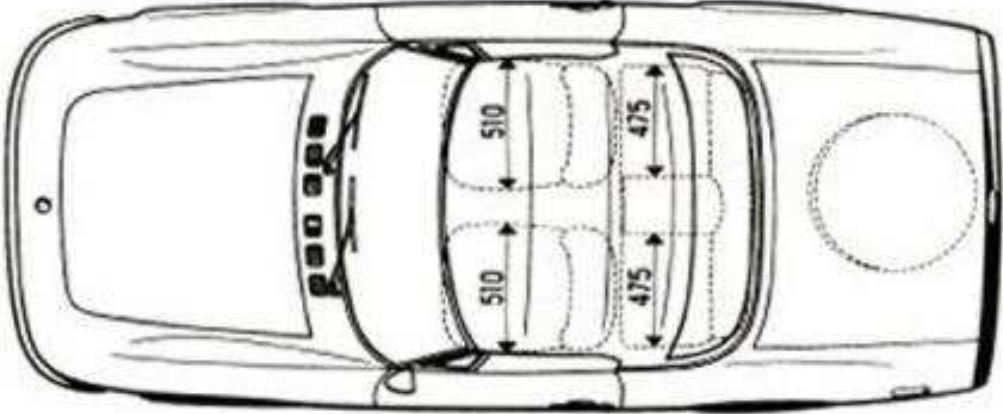

Ford Capri MkI (1969 - 1974)

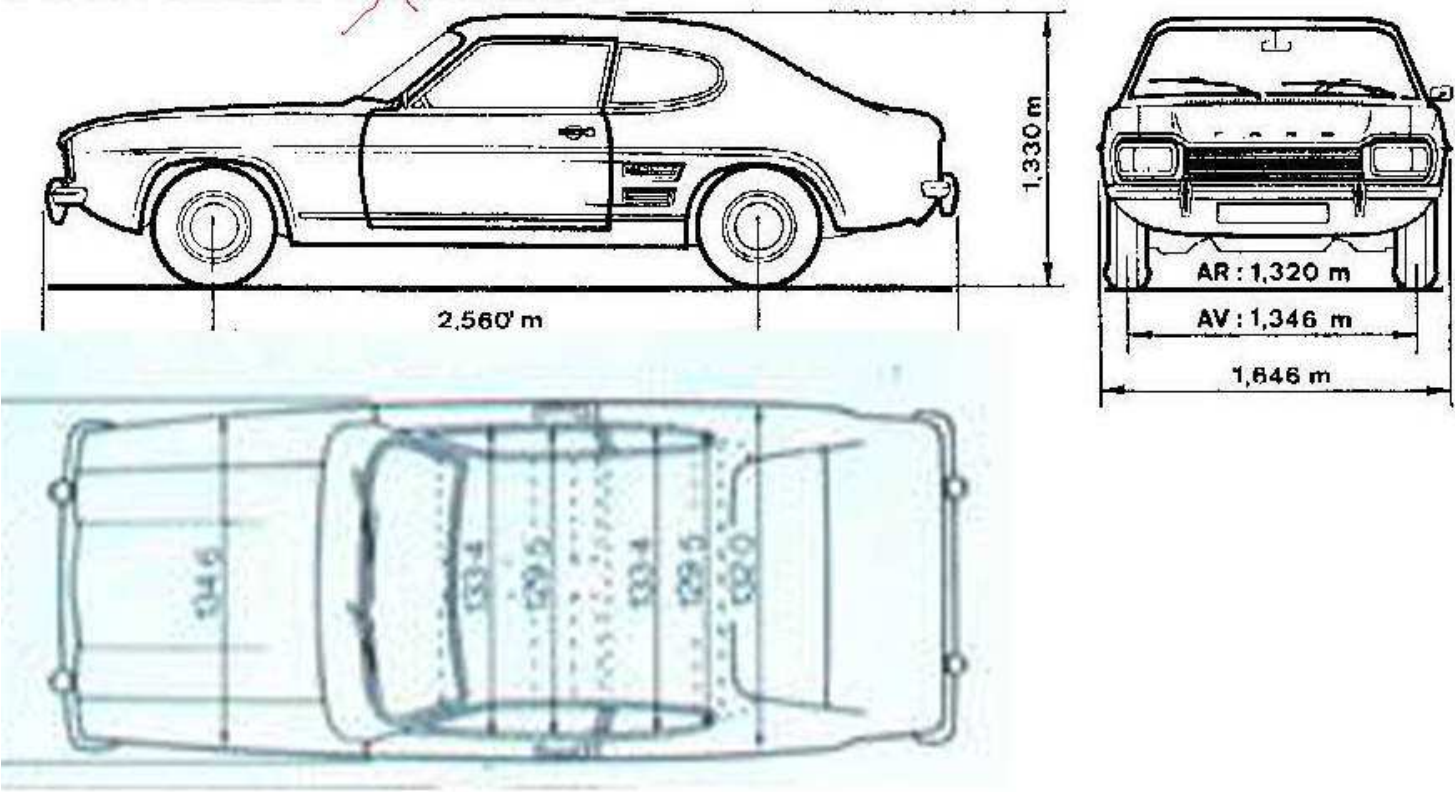

Ford Capri MkII (1974 - 1978)

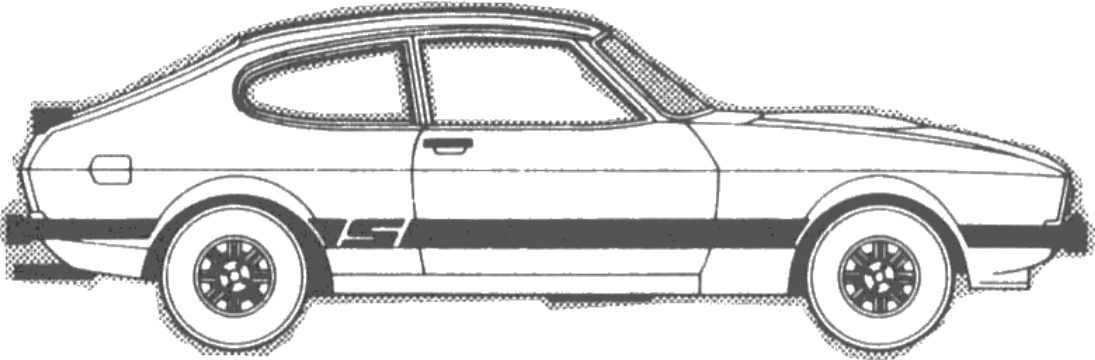
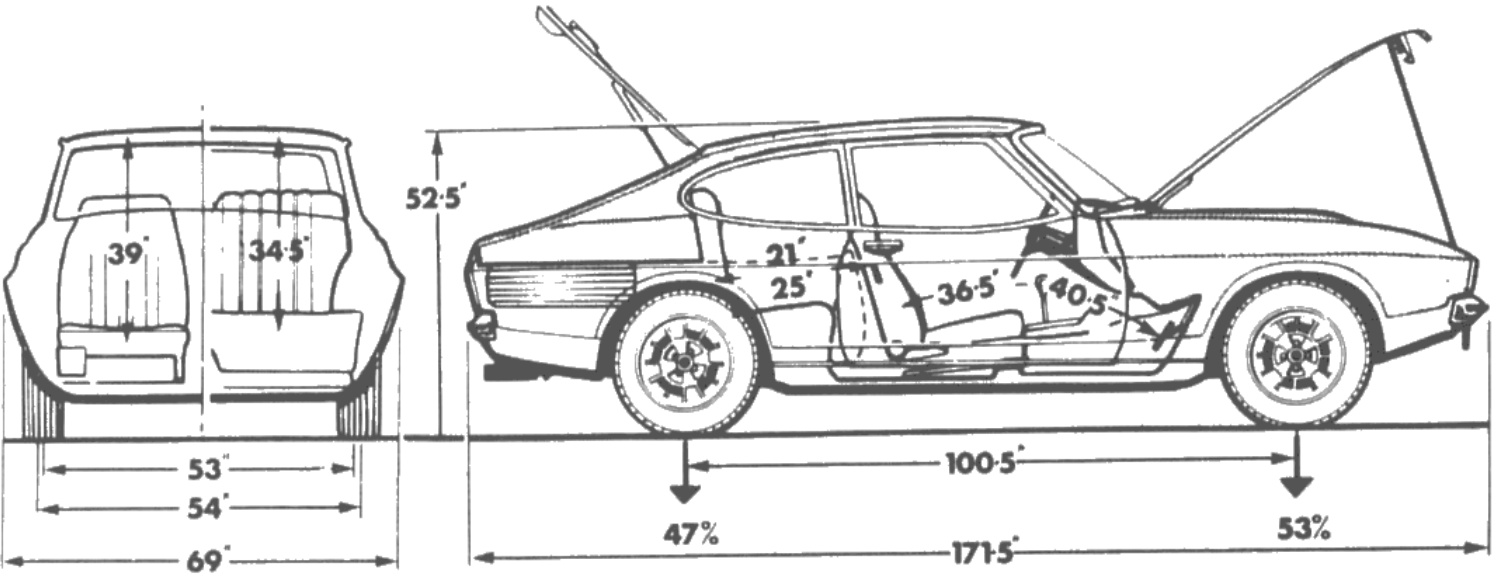

Ford Capri MkIII (1978 - 1986)

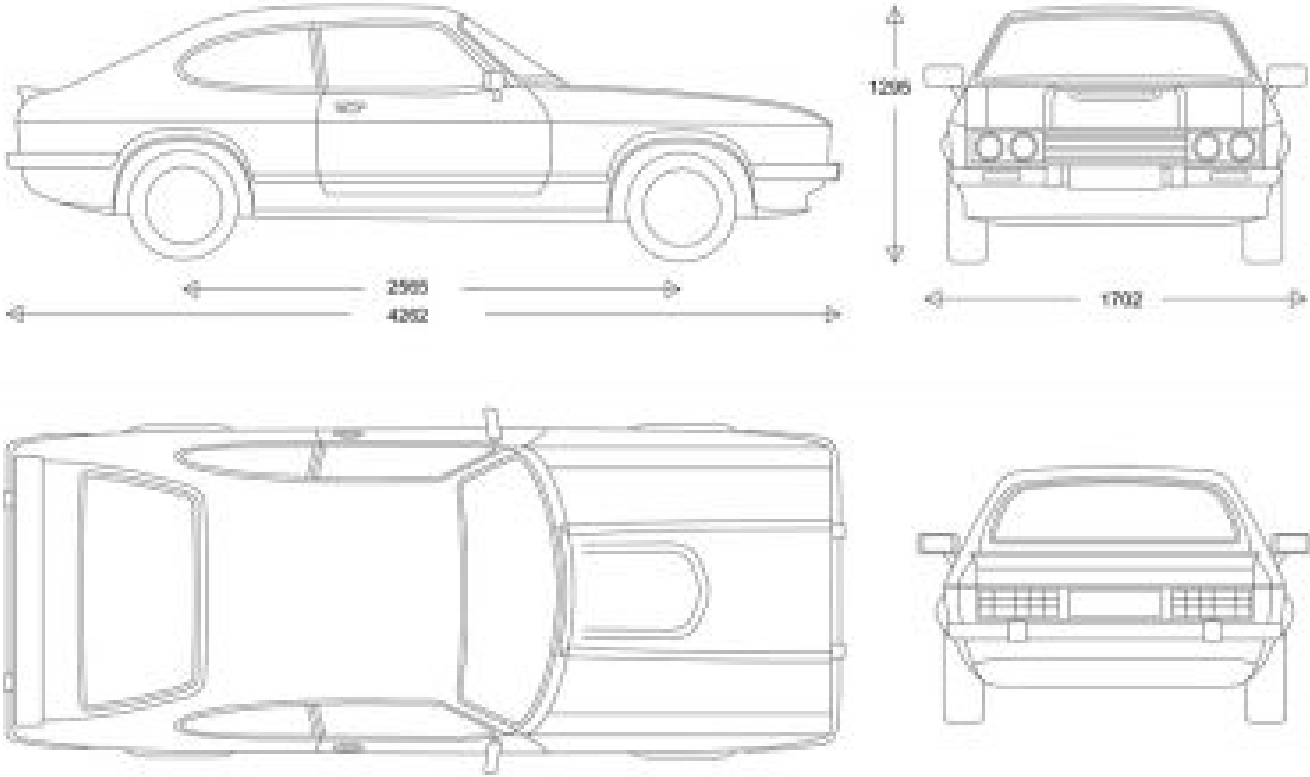

Ford Mustang (1964 - 1973)

Ford Mustang II (1974 - 1978)

Ford Mustang III (1979 - 1993)

Ford Sierra (3 puertas) (1983 - 1991)

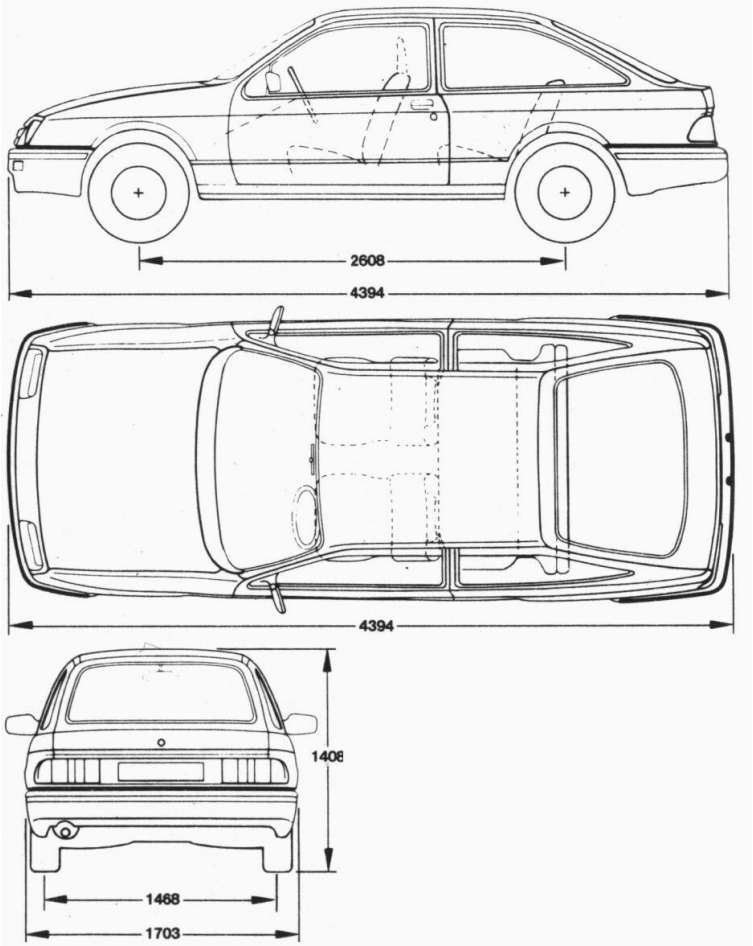

IKA-Renault Torino Coupe (1966 - 1981)

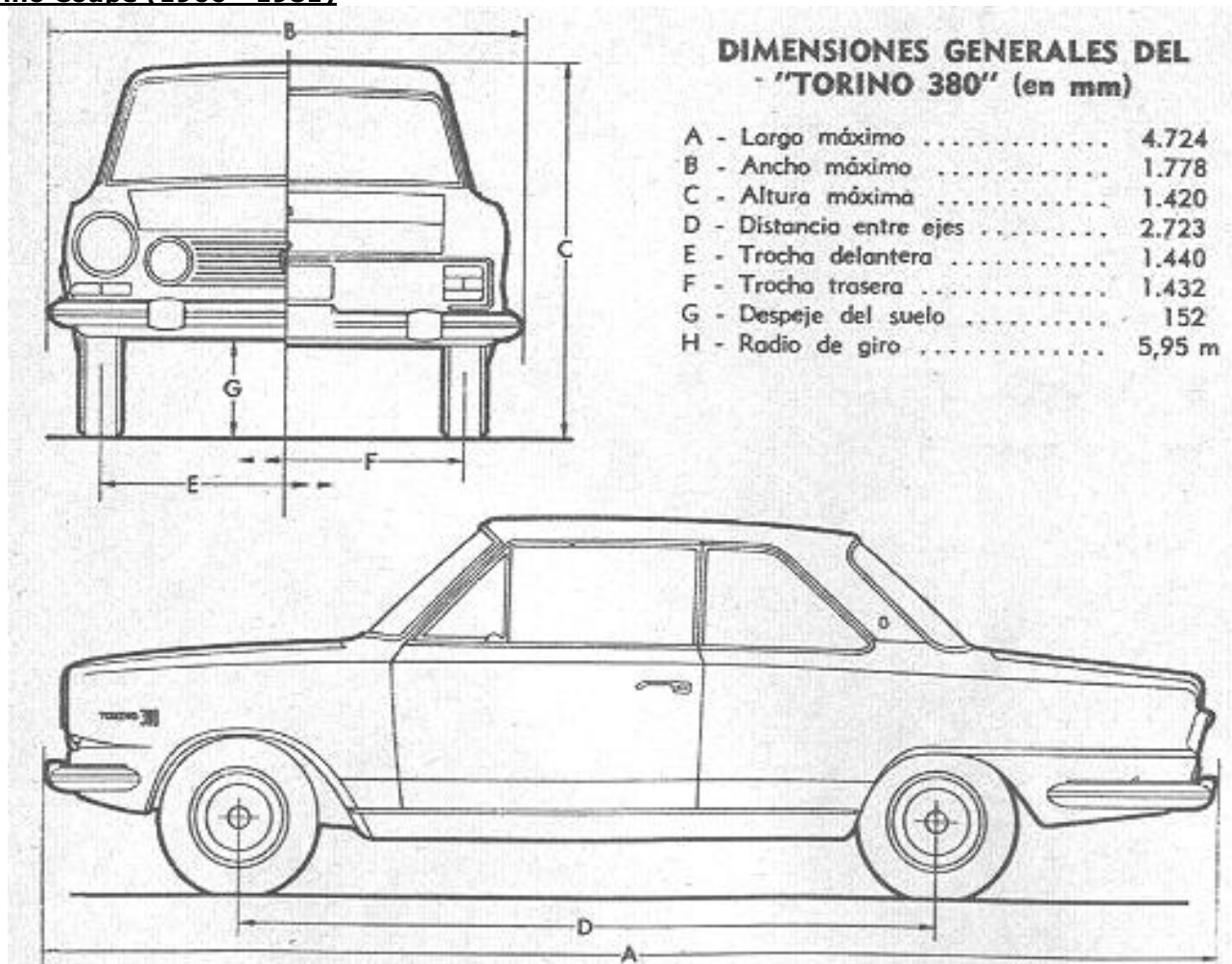

Mercedes-Benz SLC W107 (1971 - 1981)

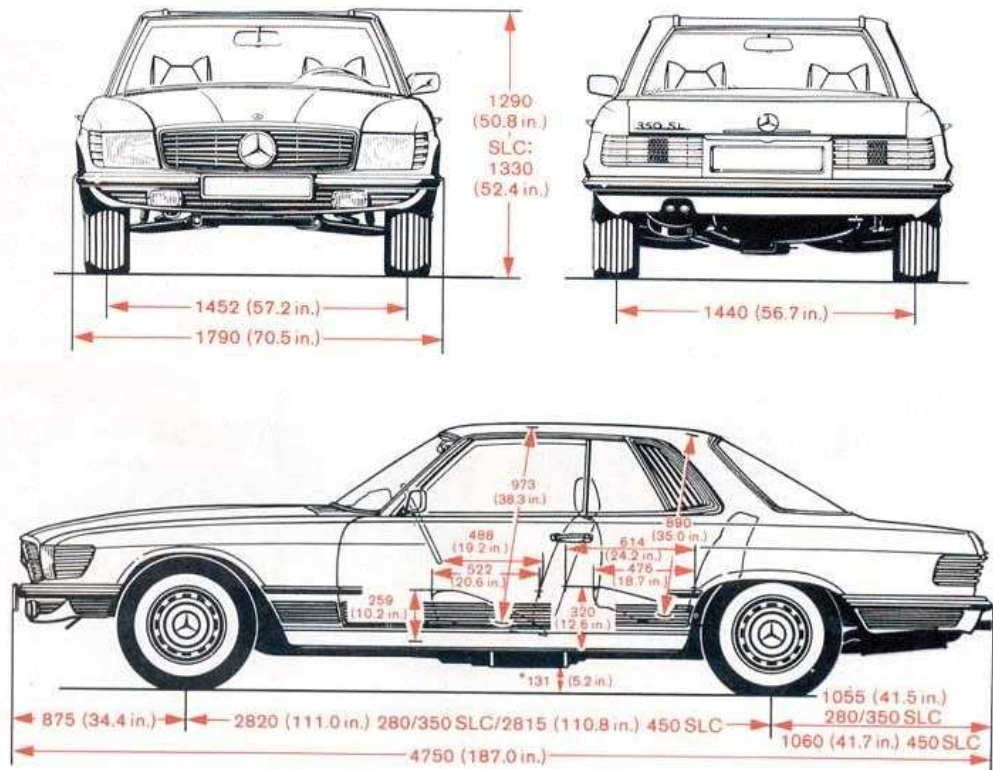

Maße unbelastet
 Dimensions unloaded
 Dimensions véhicule à vide
 Medidas sin carga
 Misure a vuoto
 Måt vid obelastad bil

* Bei Belastung mit 2 Personen à 65 kg
 Occupied with 2 persons 65 kg each
 Chargées de 2 personnes de chacune 65 kg
 Con una carga de 2 personas 65 kg cada una
 In caso di carico con 2 persone 65 kg ogni persona
 Belastning 2 personer vardera 65 kg

Mercedes-Benz 190 W201 (1982 - 1993)

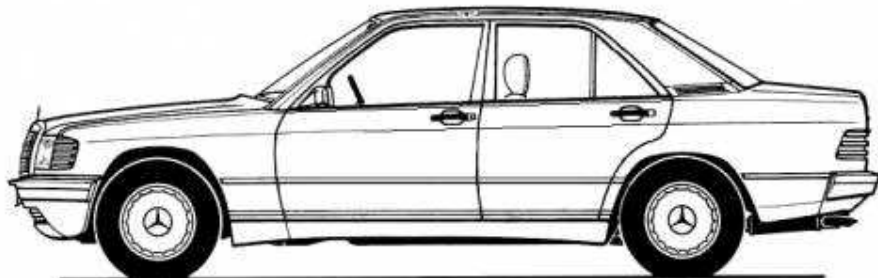
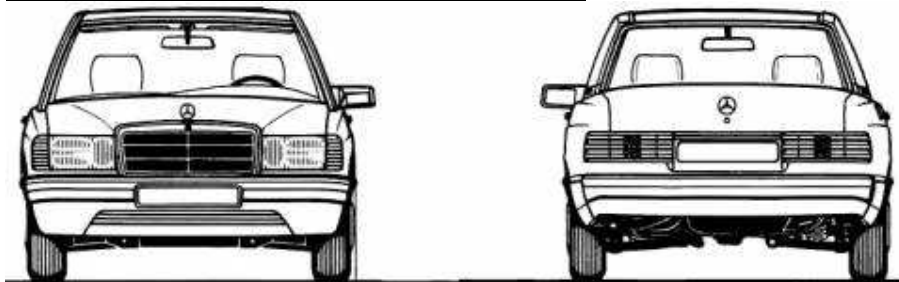

MG B GT (1965 - 1980)

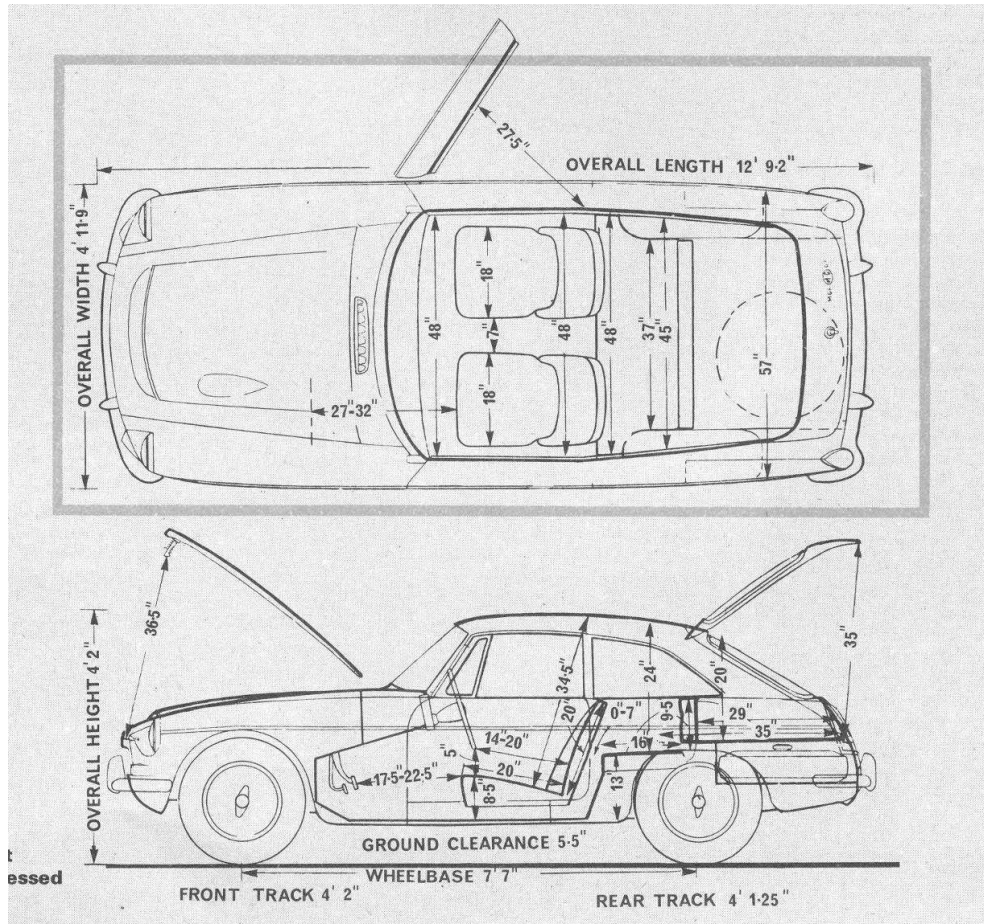

MG C (1967 - 1969)

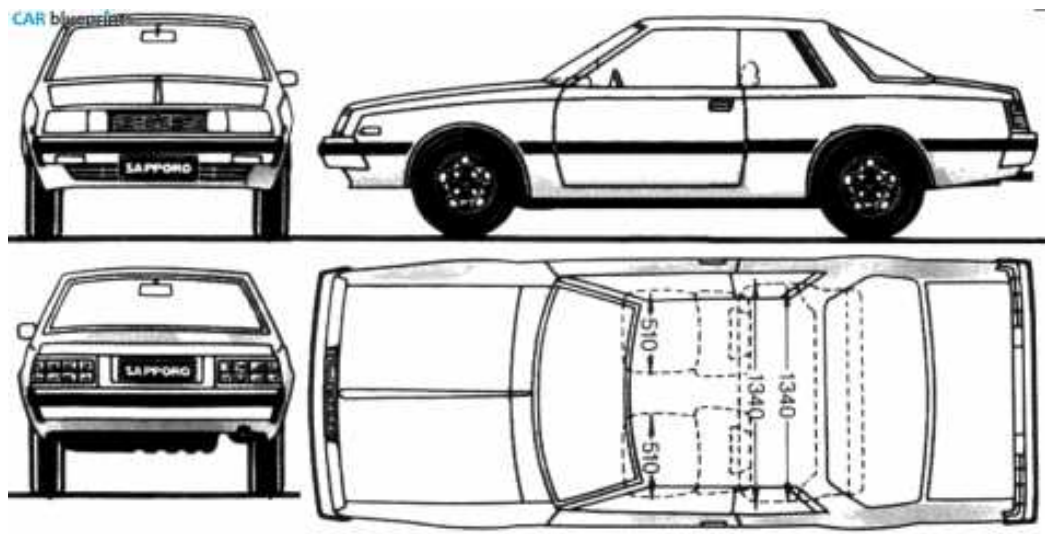

Peugeot 504 Coupé (1969 - 1983)

DIMENSIONS – DIMENSIONI

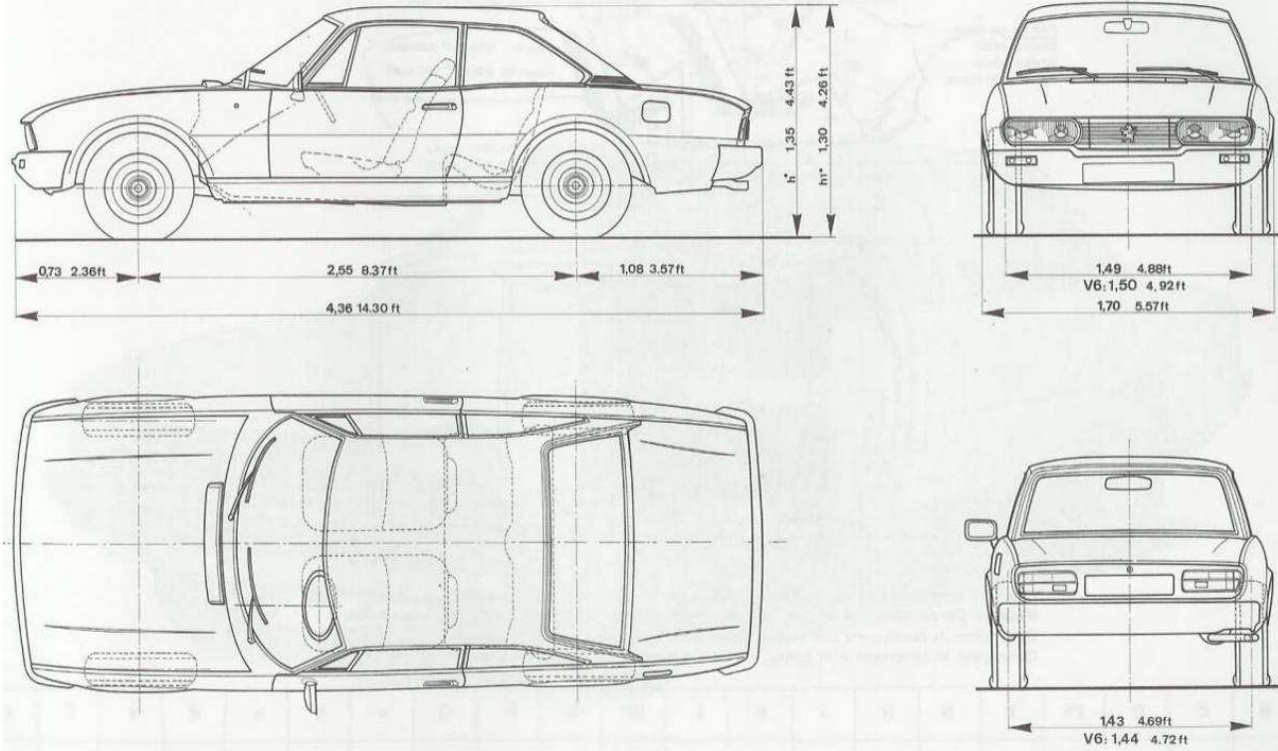

Porsche 914 (1969 - 1972)

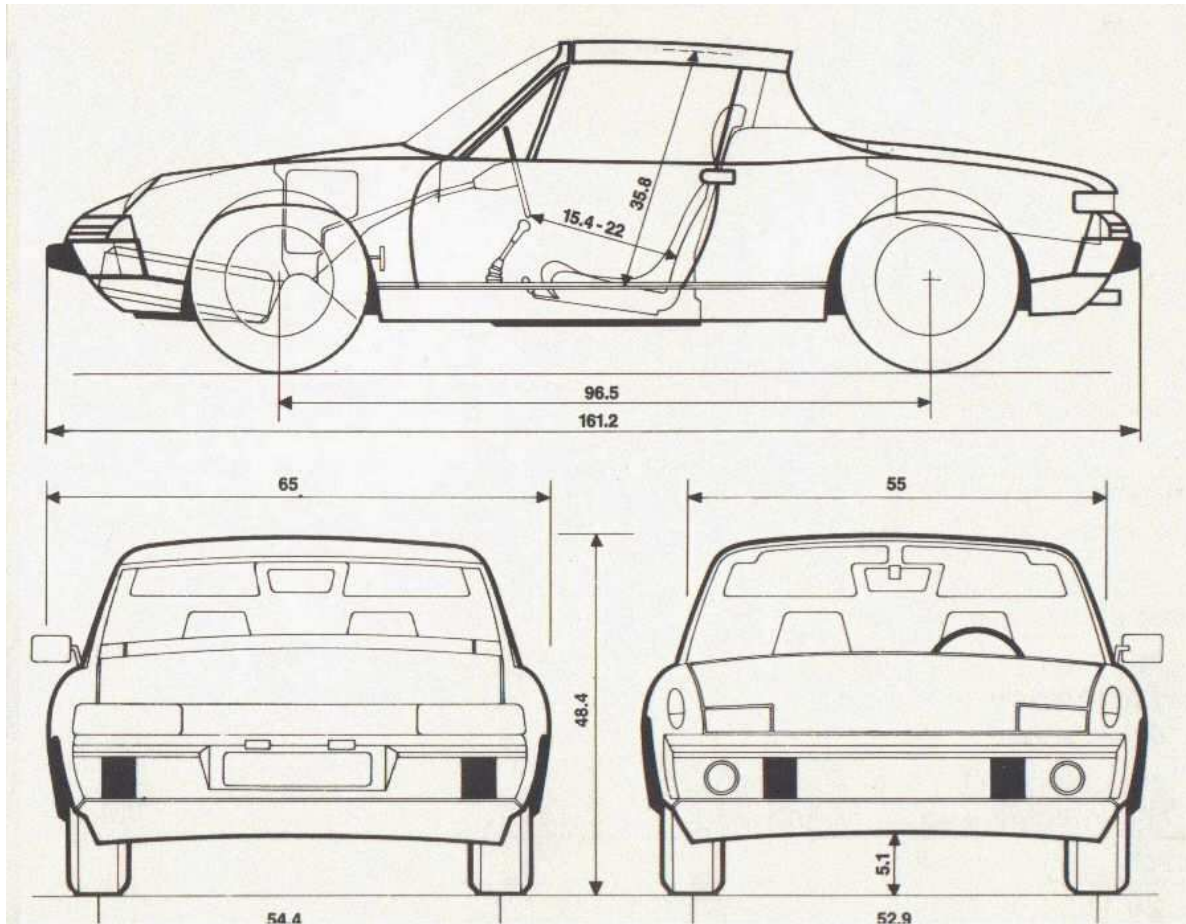

Porsche 928 (1978 - 1995)

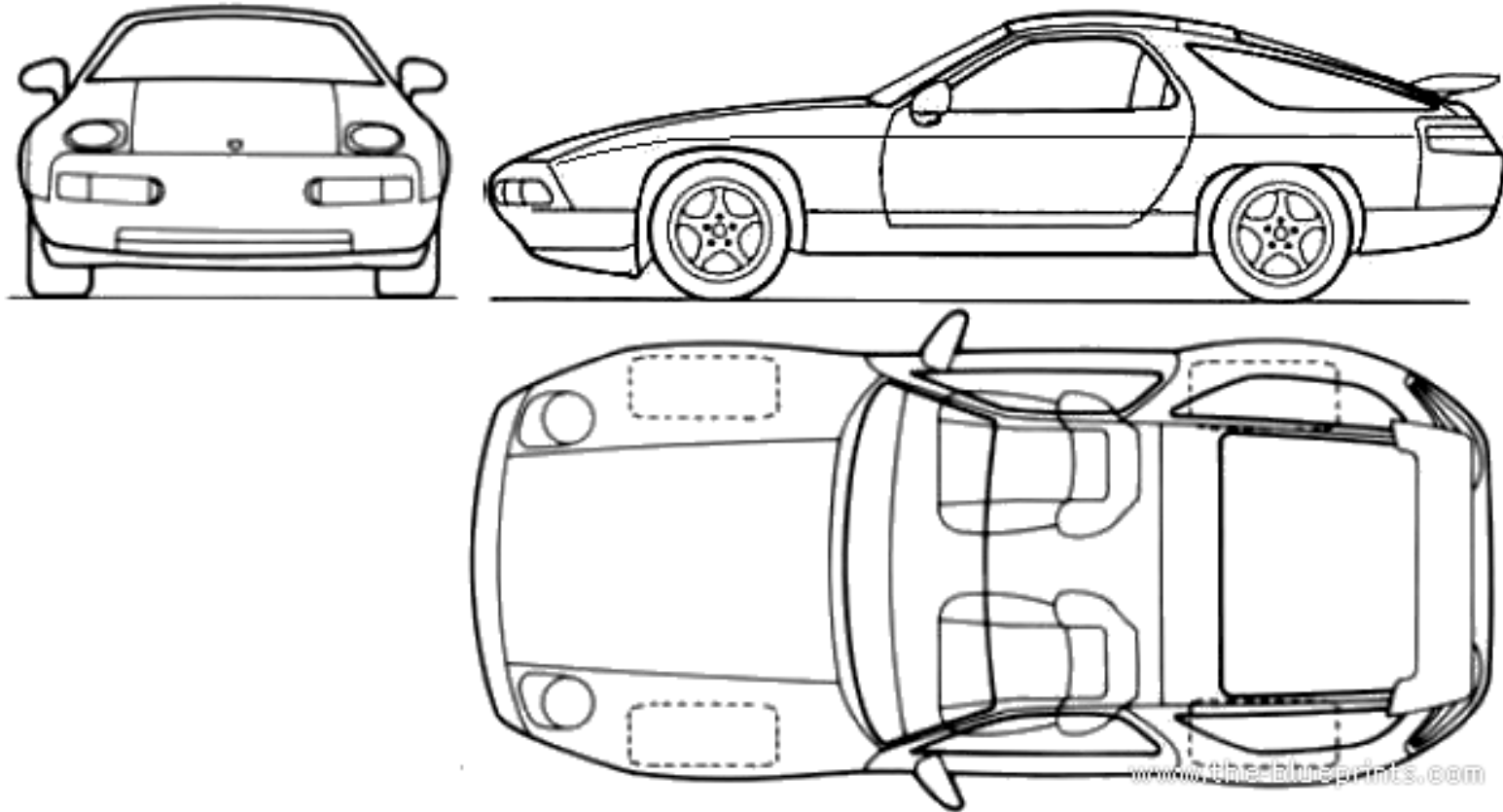

Porsche 911/901 (1963 - 1973)

Porsche 911/930 (1974 - 1988)

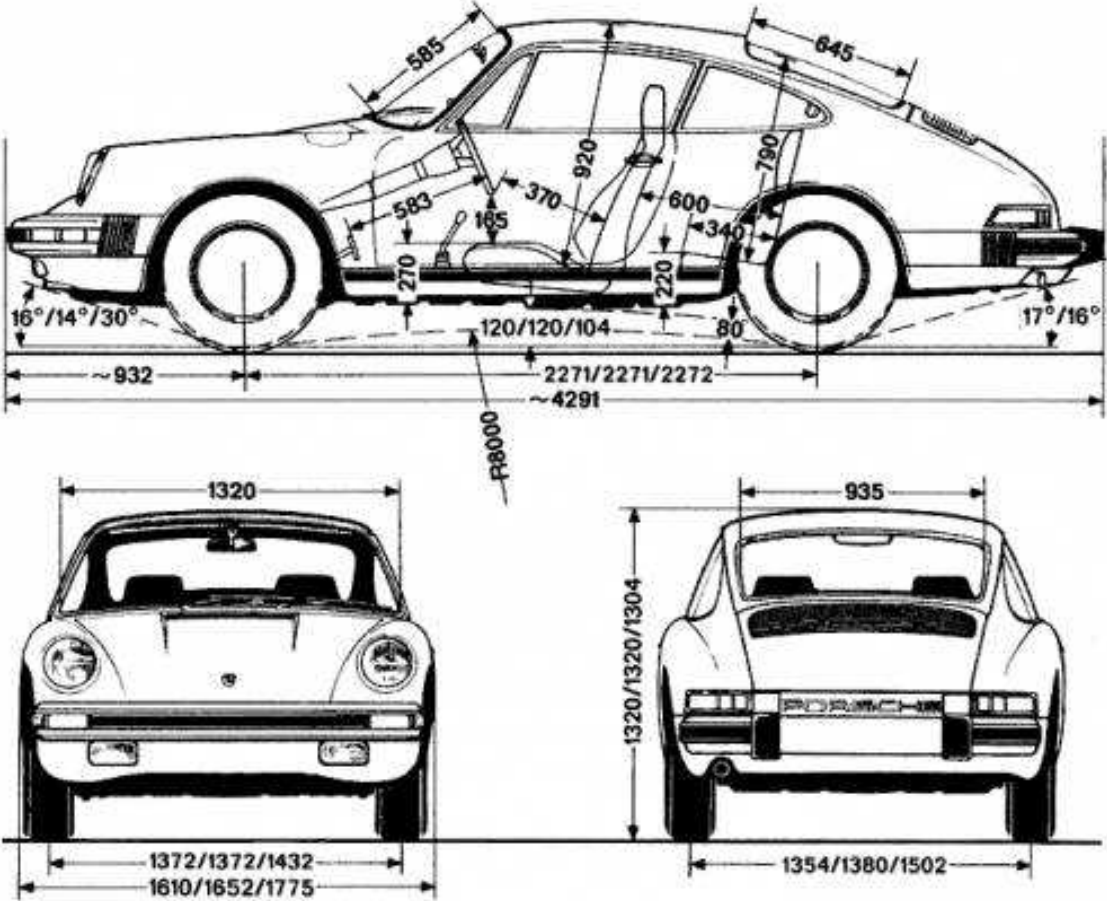

Toyota Celica Supra MkI (1979 - 1981)

Toyota Celica Supra MkII (1982 - 1986)

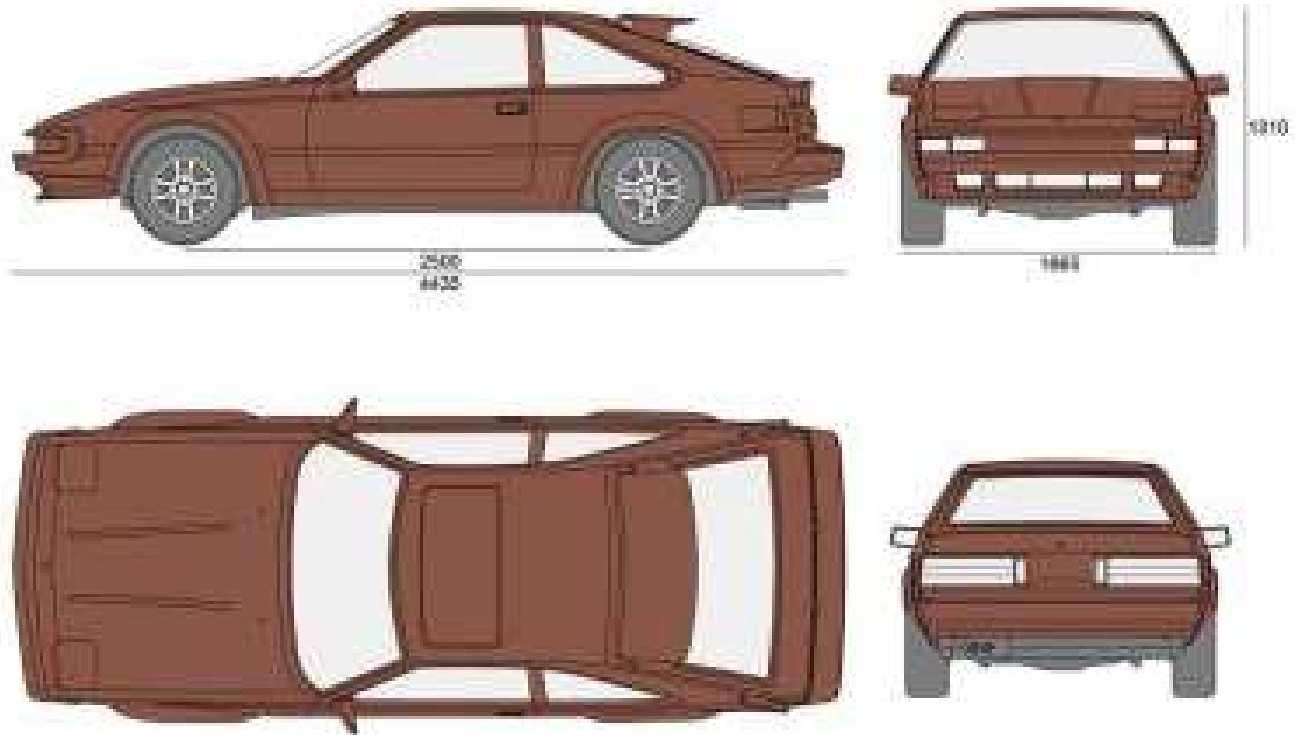

Volvo 262 (1975 - 1984)

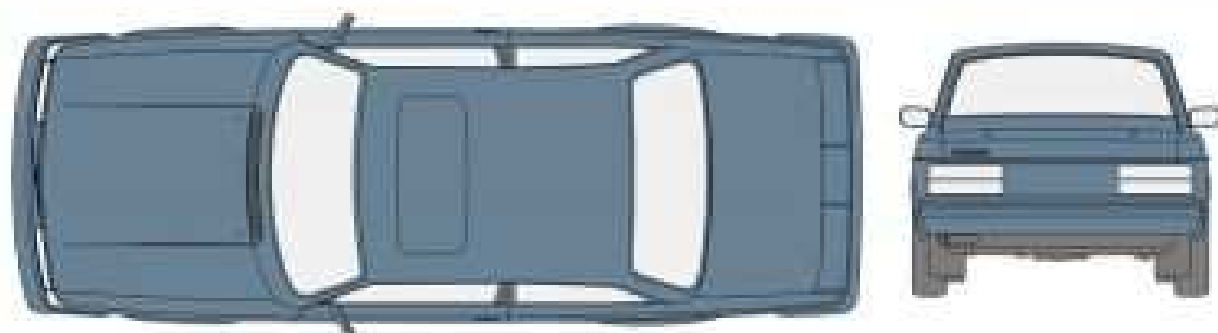

FIGURINES DEMÁS VEHICULOS GT

Alfa-Romeo Alfasud Sprint (1976 - 1989)

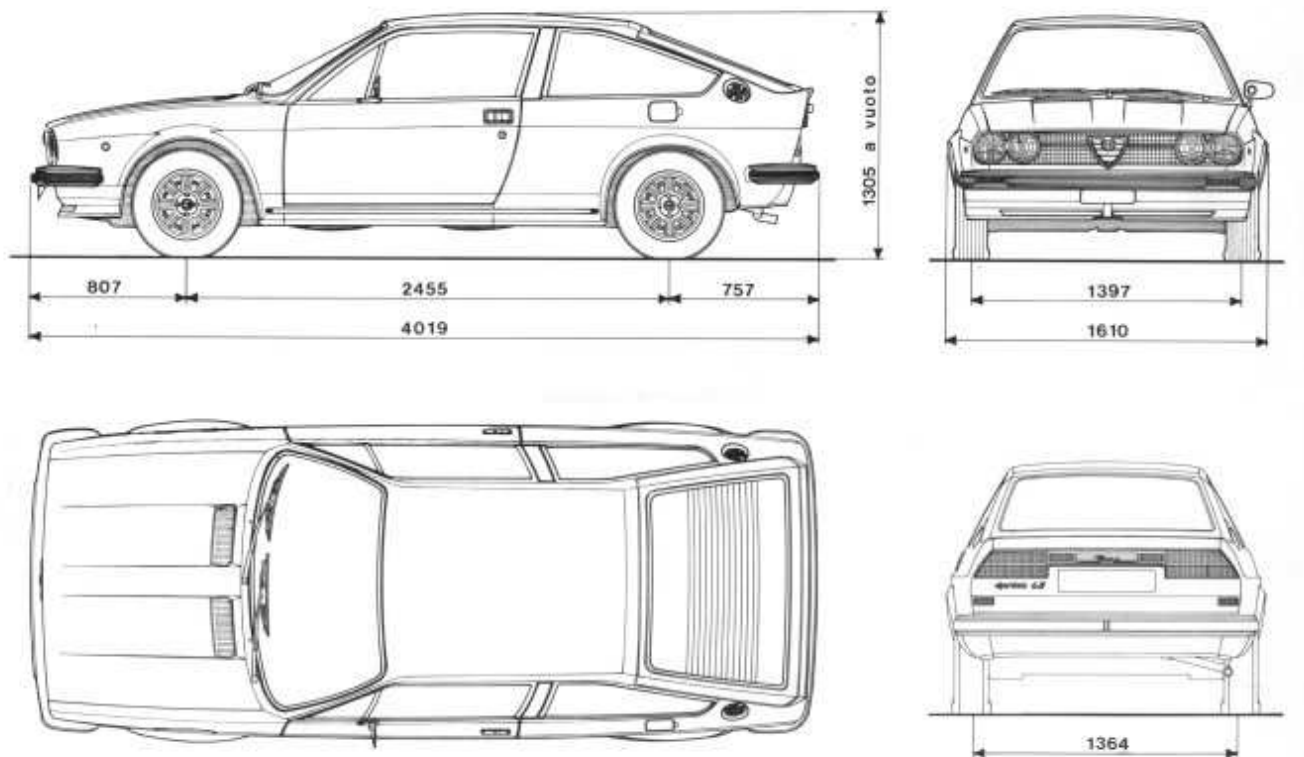

Alfa-Romeo Alfasud ti (1973 - 1984)

Alfa-Romeo Alfetta GT / GTV (4 cilindros) (1974 - 1986)

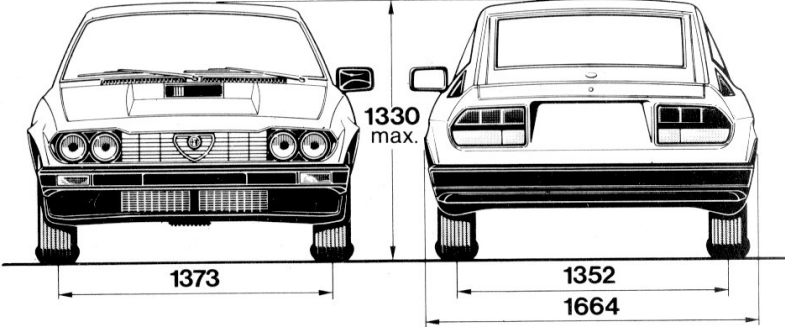
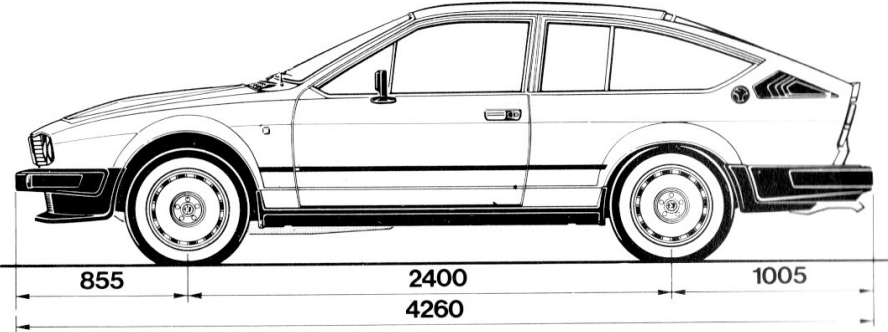

Alfa-Romeo Duetto Spider (1966 - 1969)

Alfa-Romeo Giulietta/Giulia Spider 101 (1955 - 1965)

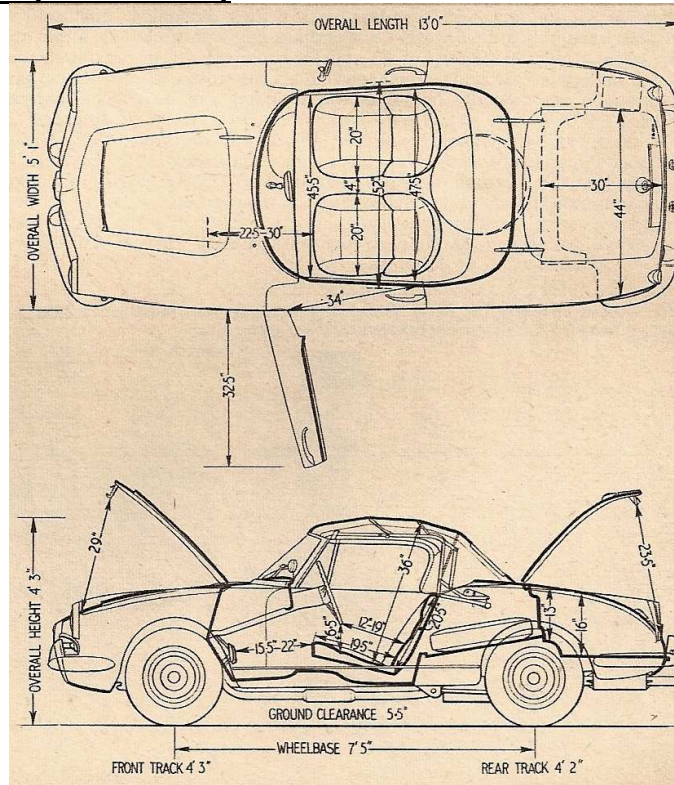

Alfa-Romeo Giulietta/Giulia Sprint 101 (1954 - 1964)

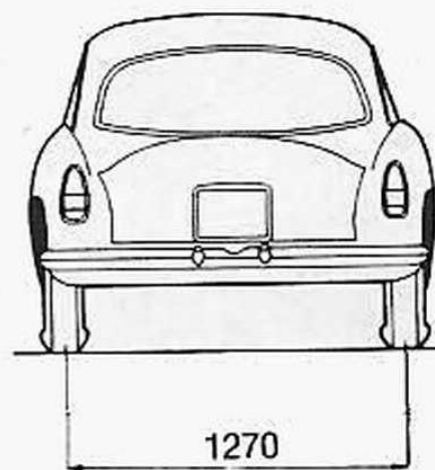
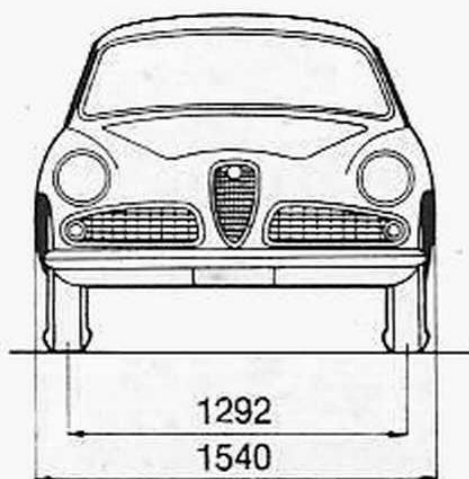
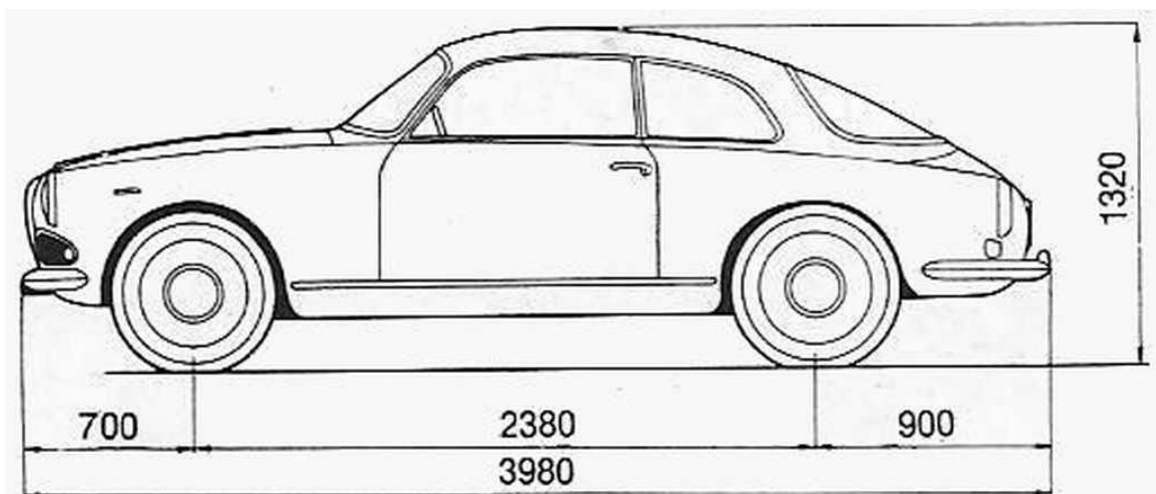

Alfa-Romeo Giulia Sprint 105 (1963 - 1976)

Alfa-Romeo Giulietta 116 (1977 - 1985)

Alfa-Romeo Spider Veloce (1970 - 1994)

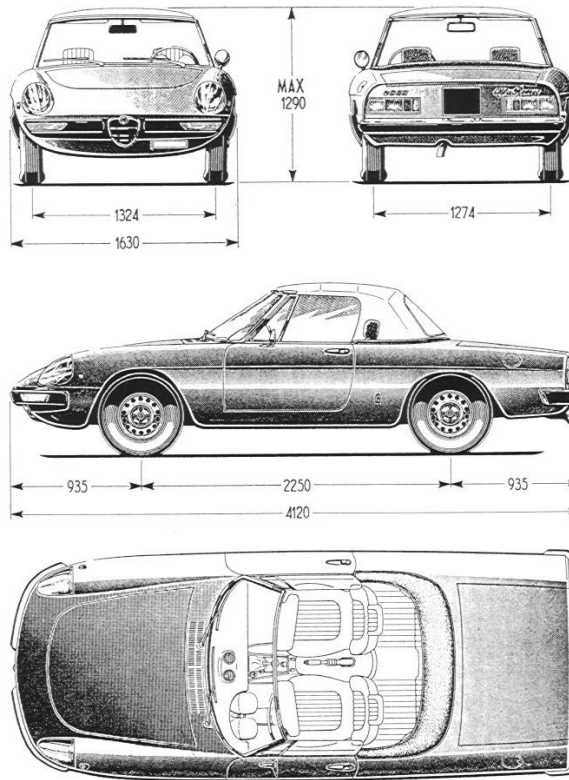

Bertone X1/9 (1982 - 1989)

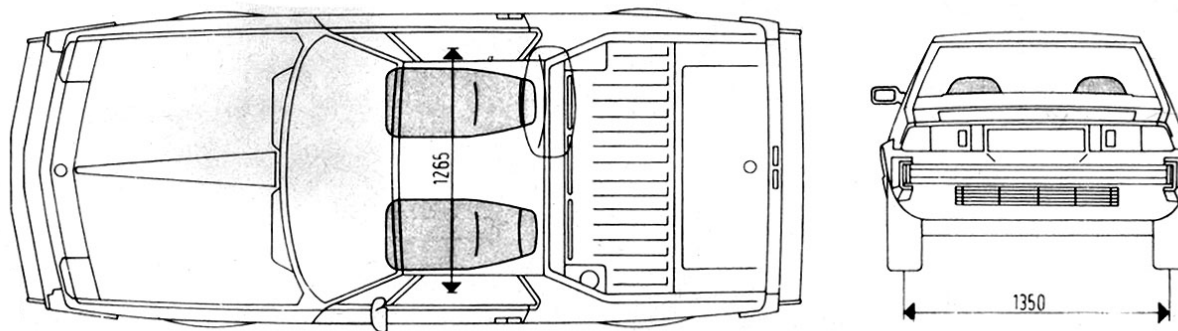
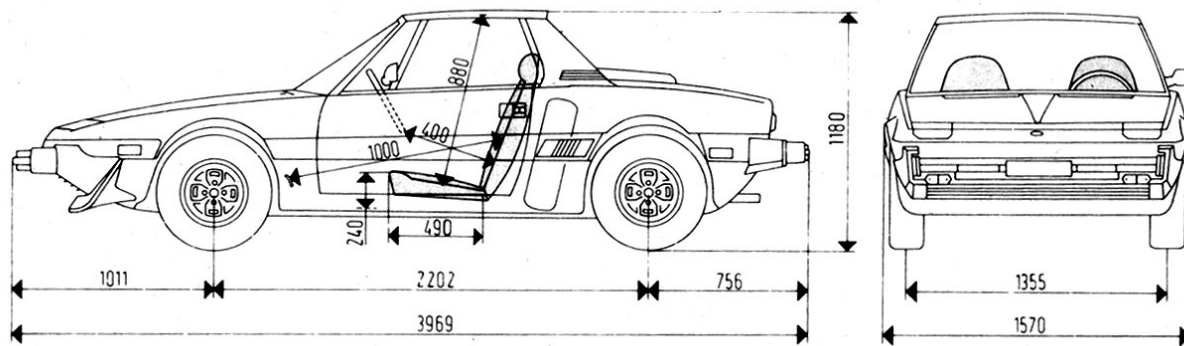

BMW 1602 (1966 - 1975)

BMW 2002 (1968 - 1976)

BMW serie 3 E21 (4 cilindros) (1975 - 1983)

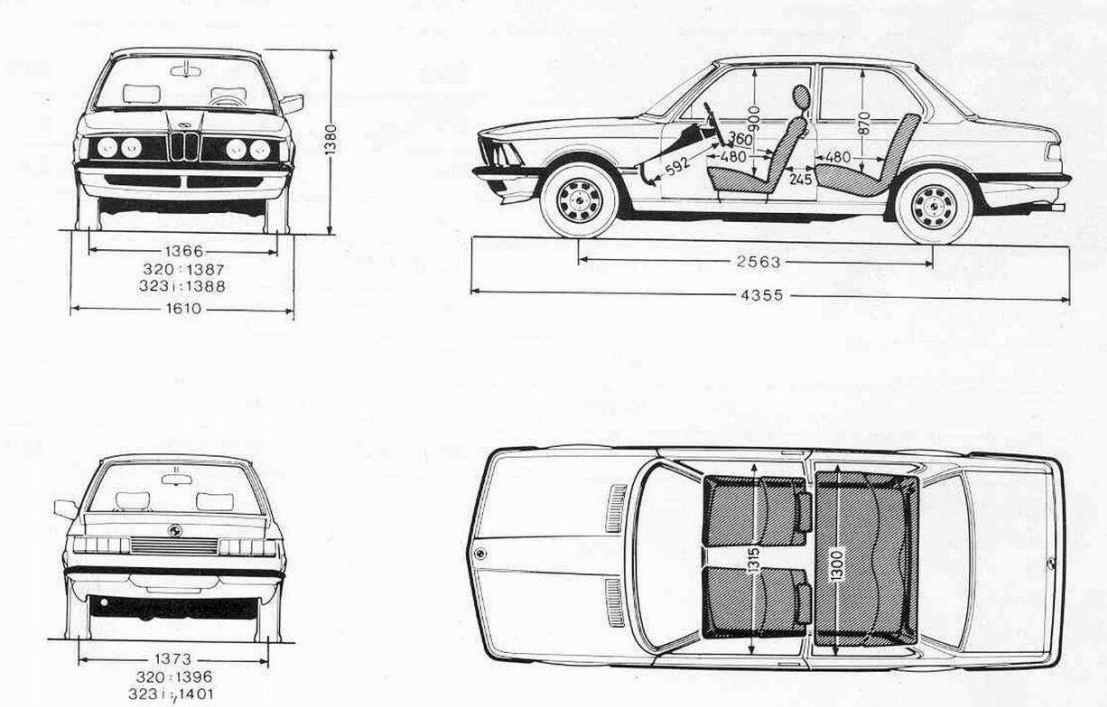

BMW serie 3 E30 (4 cilindros - 2 puertas) (1982 - 1991)

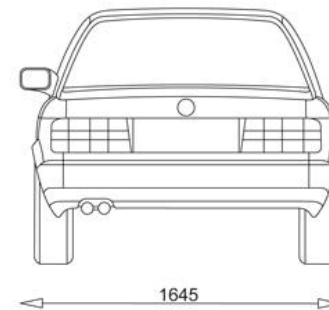
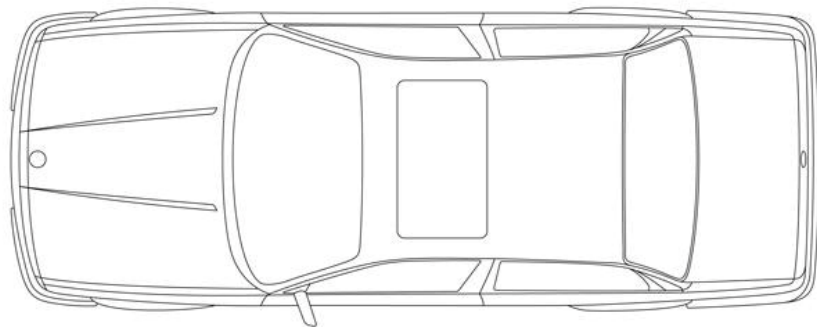
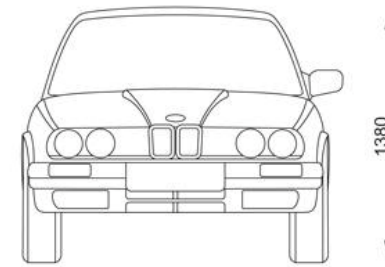
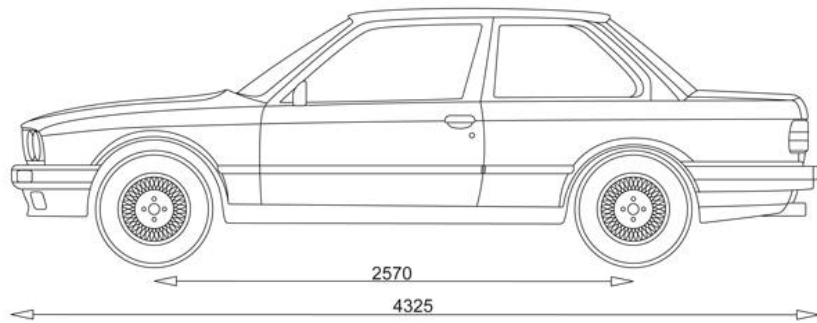

Fiat 124 Abarth Rally (1972 - 1975)

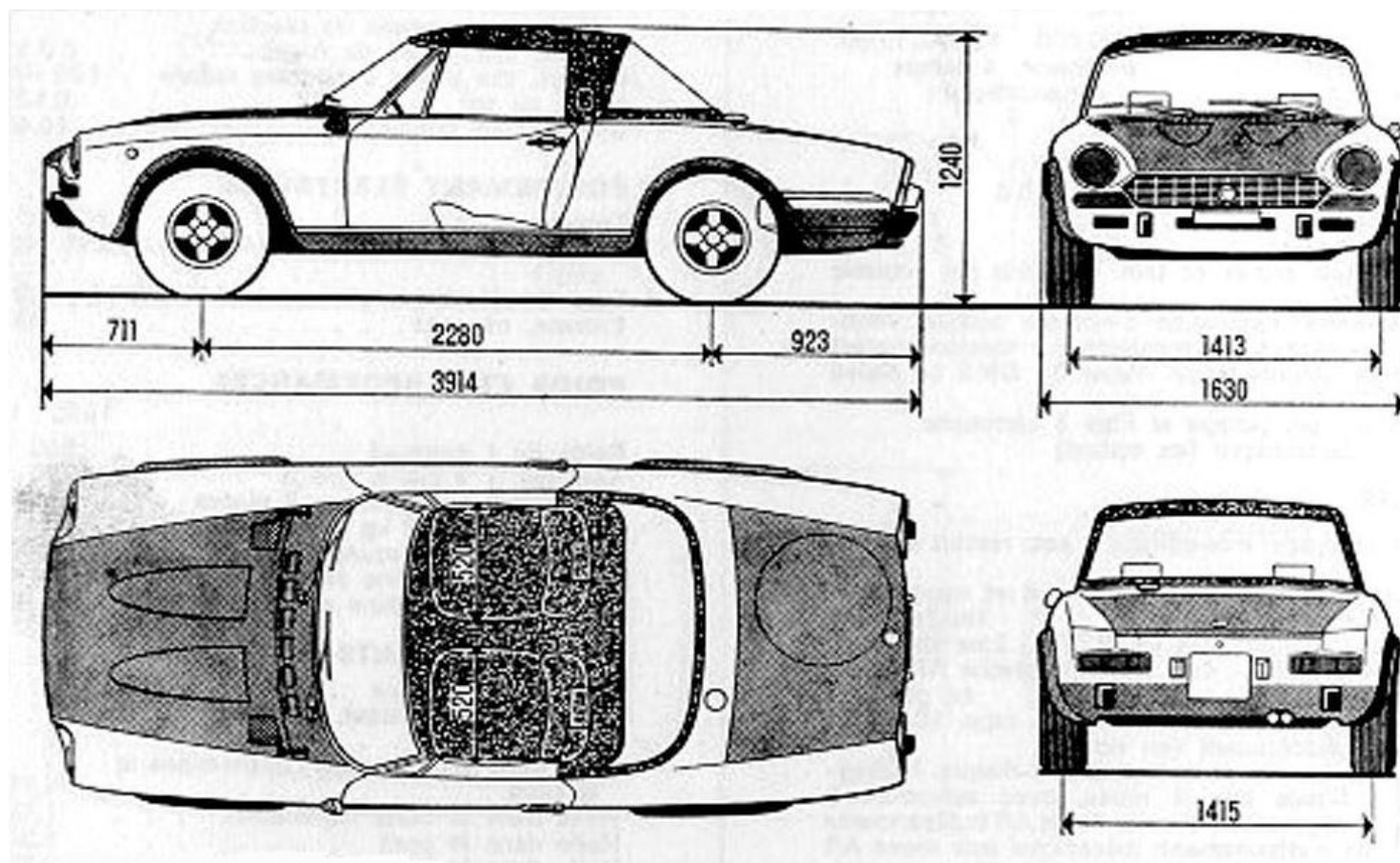

Fiat 124 Sport Coupé (1967 - 1975)

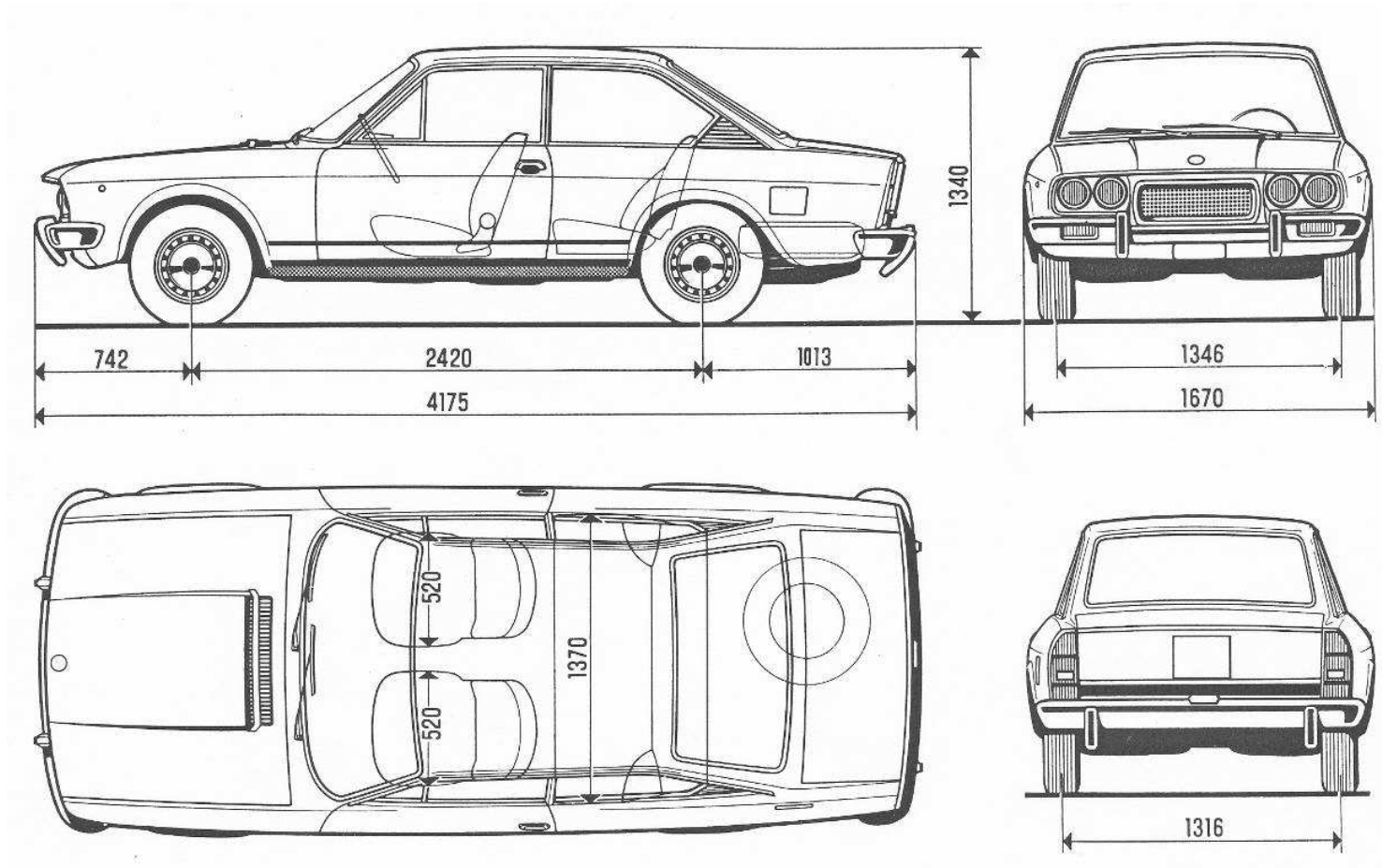

Fiat 124 Sport Spider (1966 - 1985)

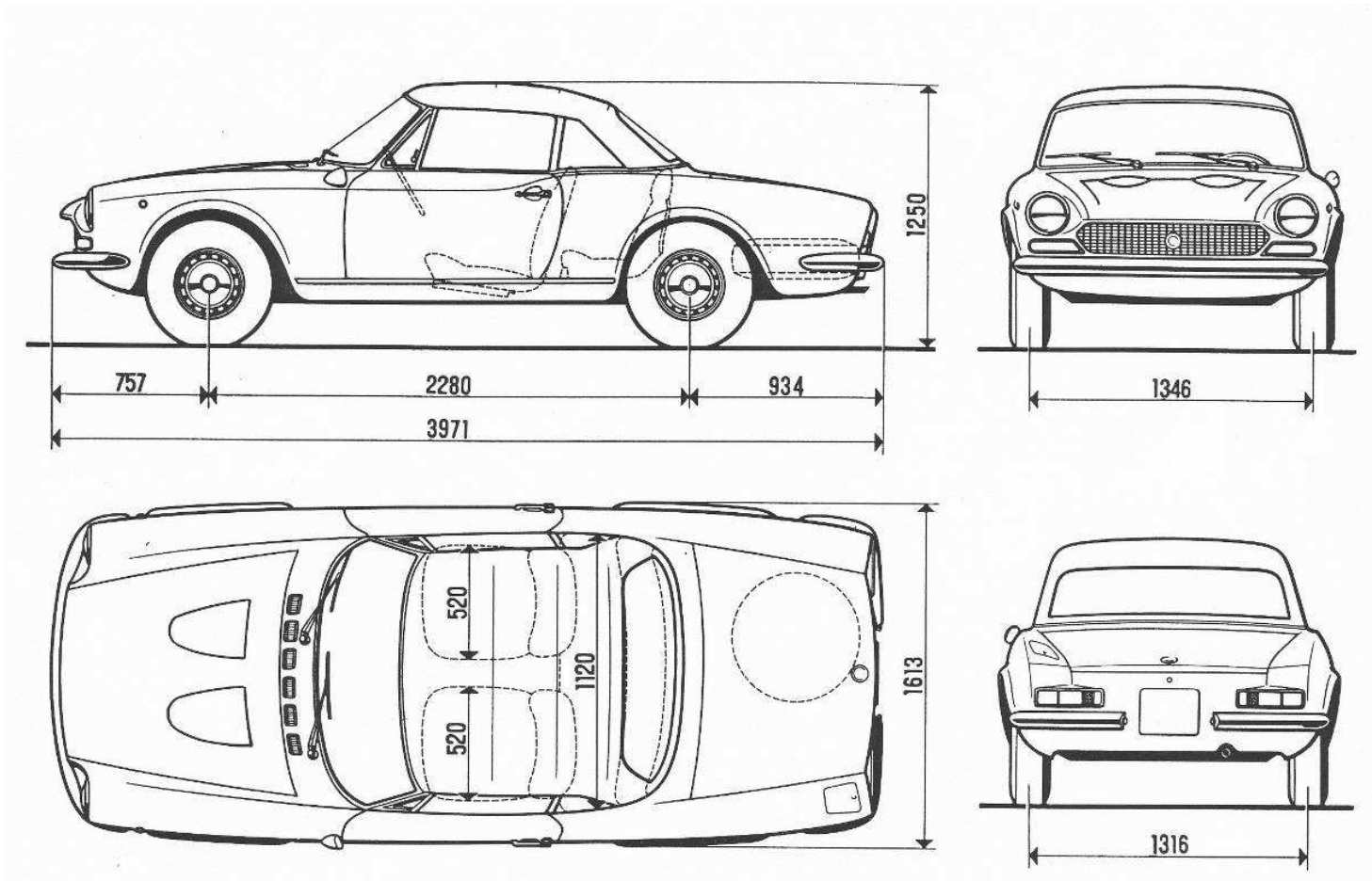

Fiat 125 Sport (1972 - 1978)

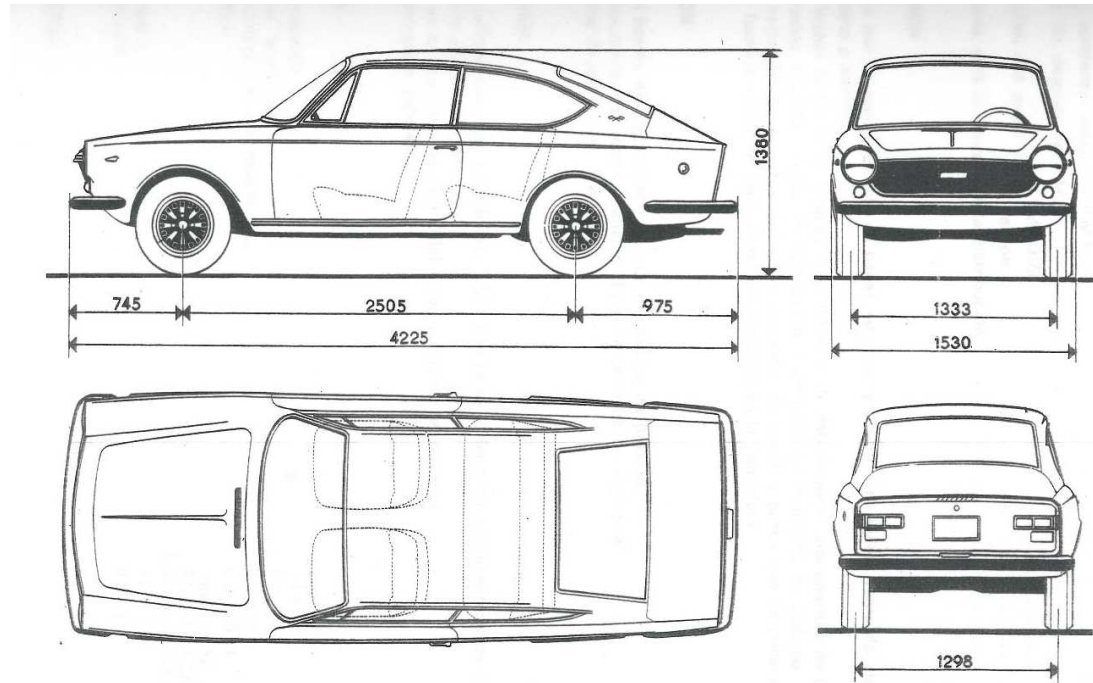

Fiat 128 Sport Coupé (1971 - 1979)

Fiat 131 Abarth (1976 - 1978)

Fiat 131 Racing (1978 - 1981)

Fiat 1500 Coupé (1966 - 1970)

Fiat 1600 Sport (1970 - 1972)

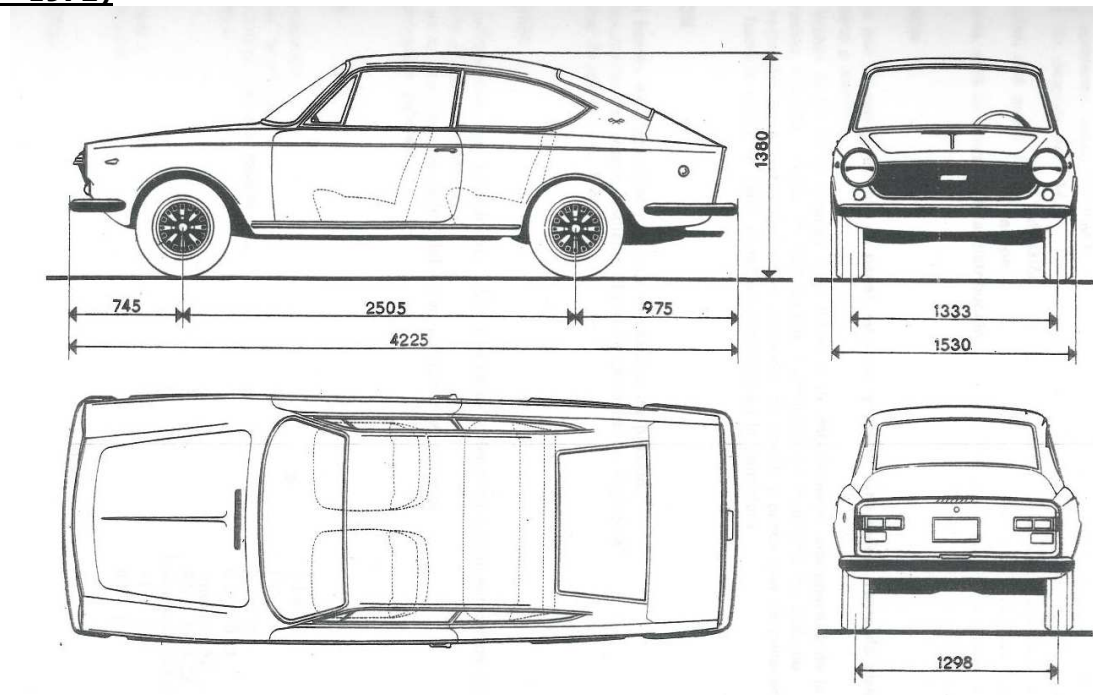

Fiat X1/9 (1972 - 1989)

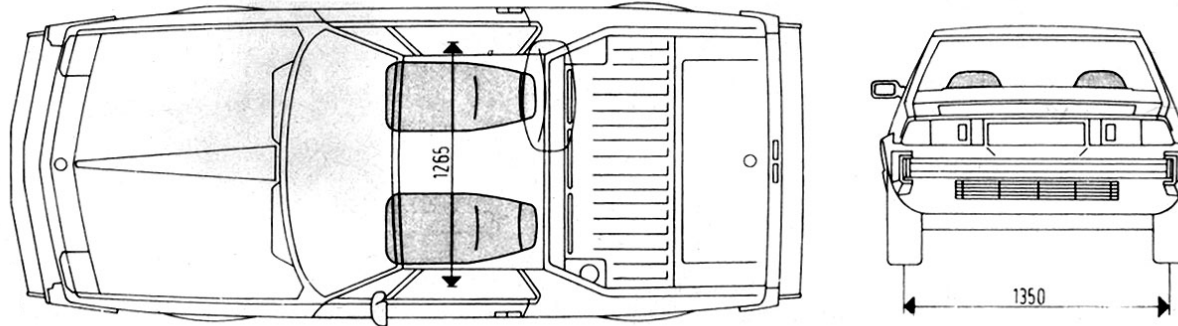
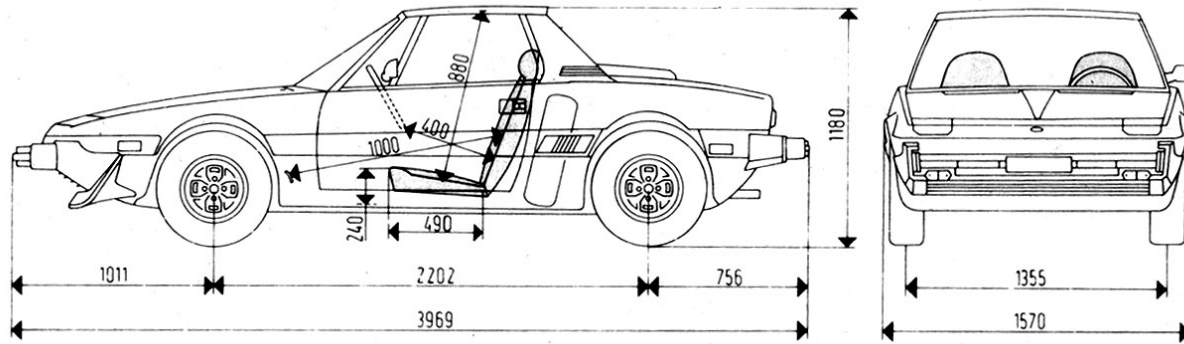

Ford Capri MkI (1969 - 1974)

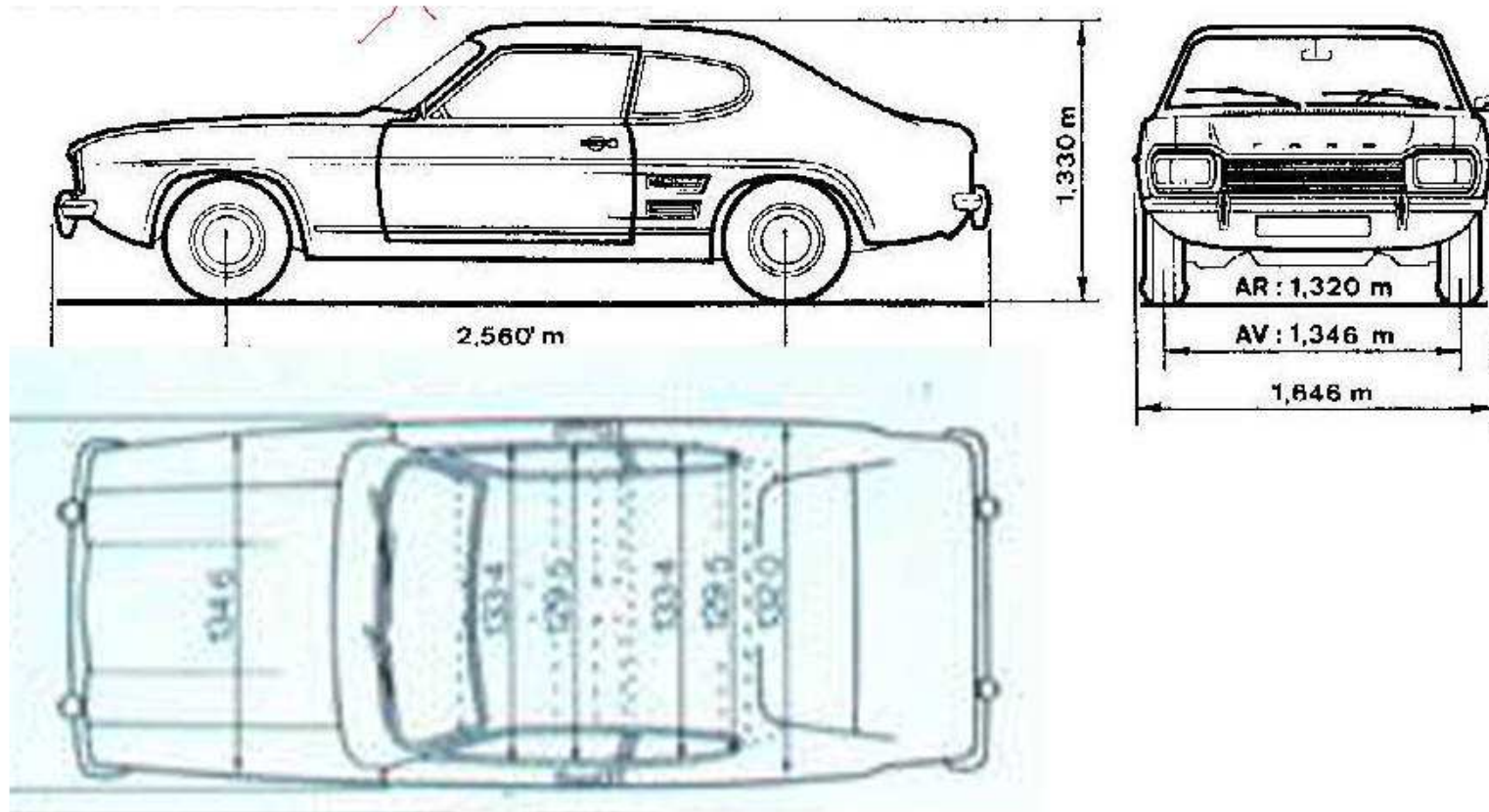

Ford Capri MkII (1974 - 1978)

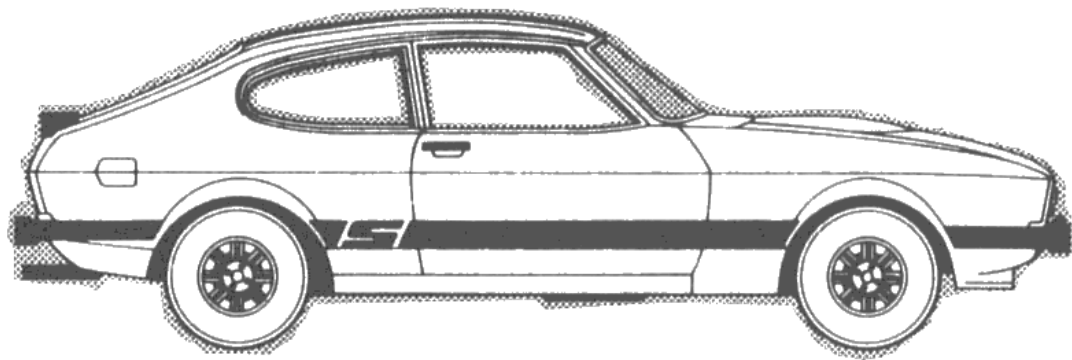
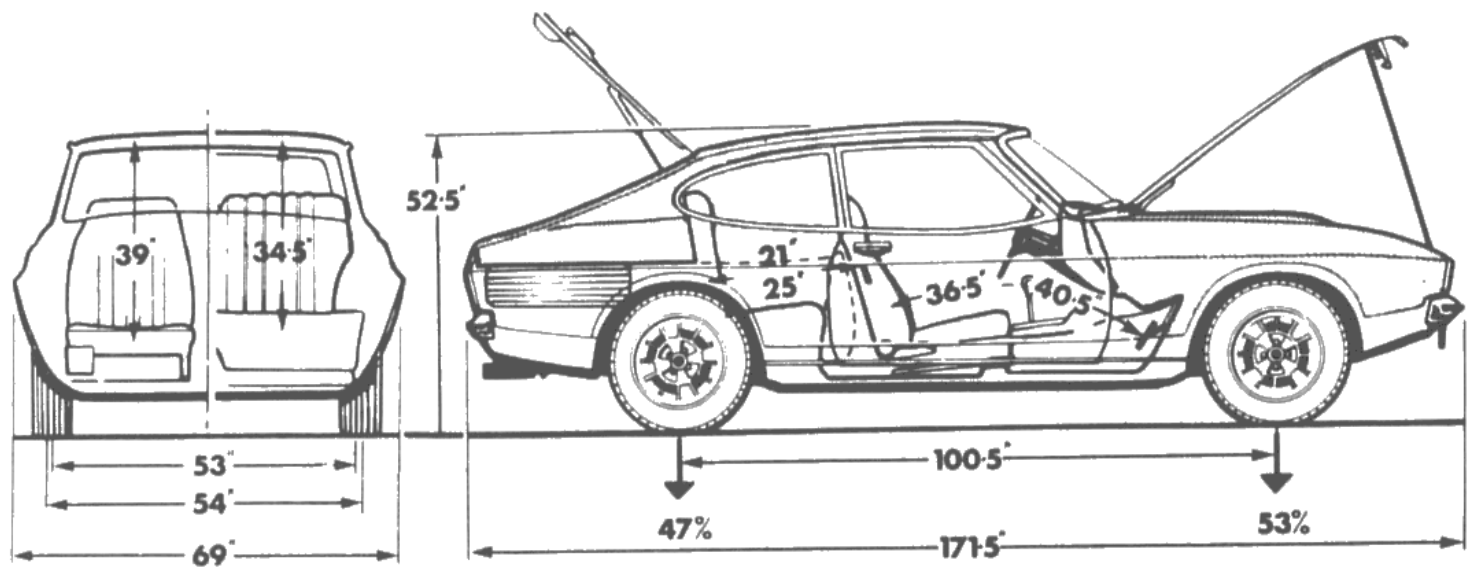

Ford Capri MkIII (1978 - 1986)

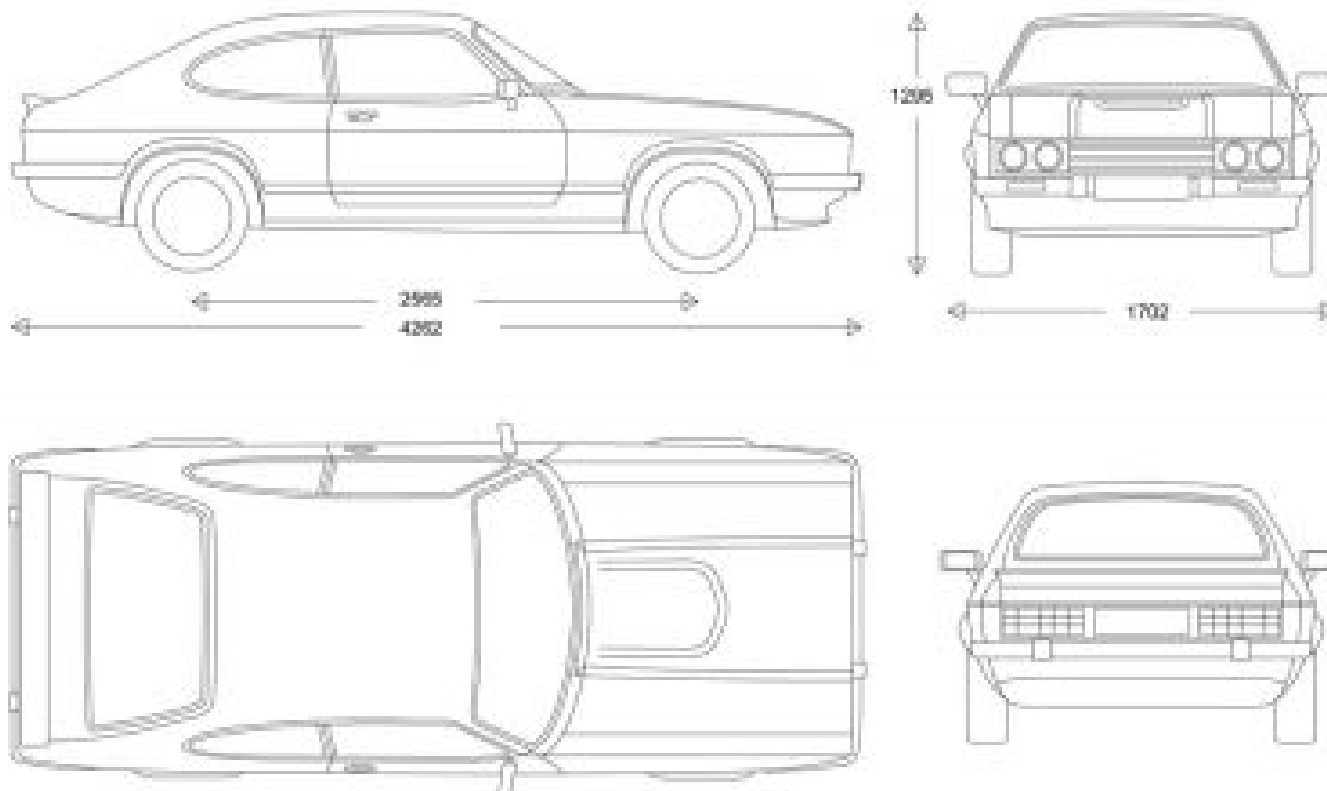

Ford Cortina Mark I (2 puertas) (1962 - 1966)

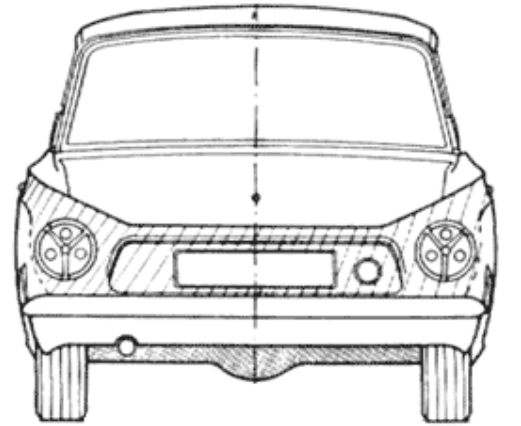
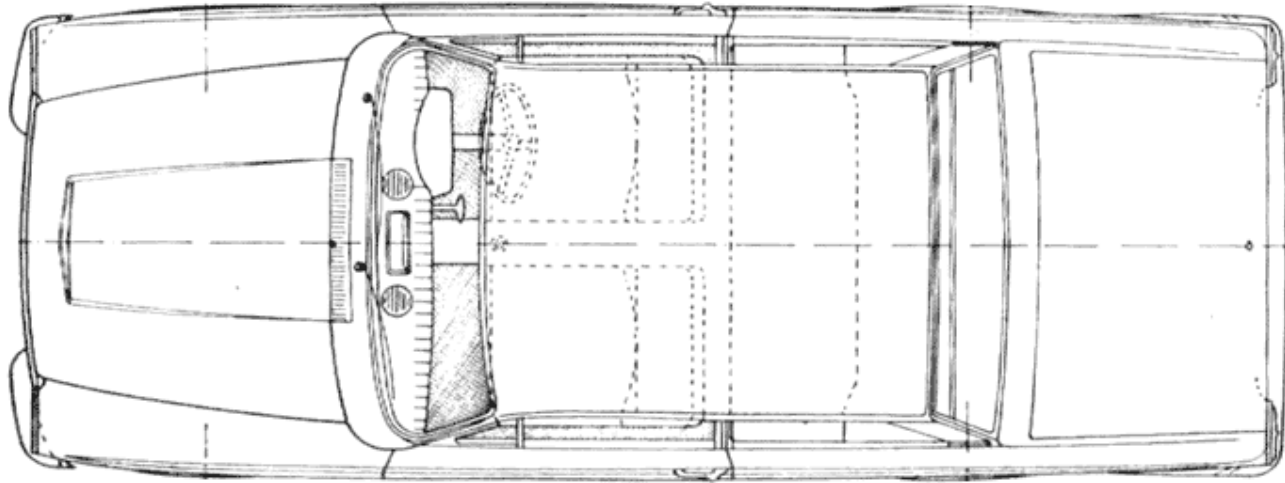
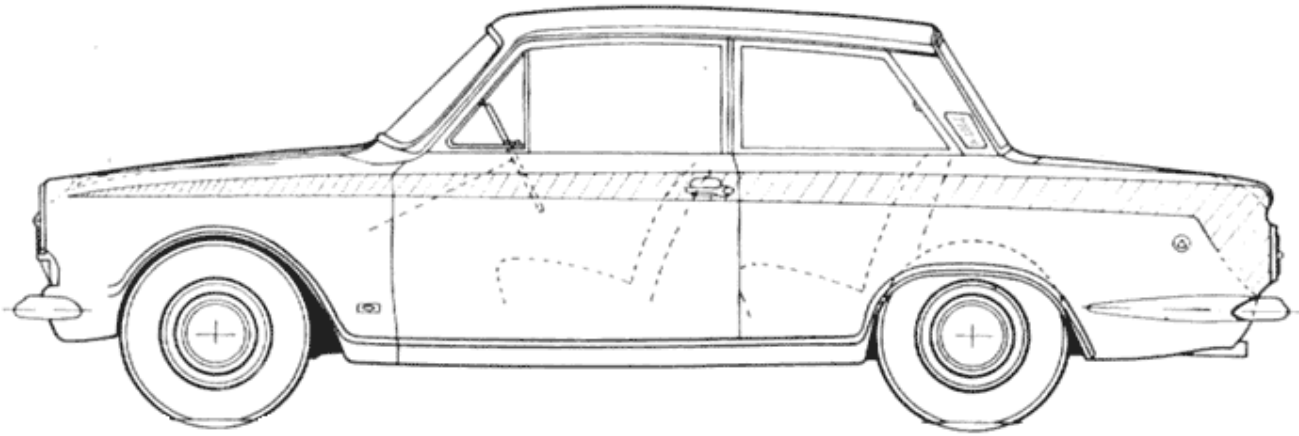

Ford Escort Mark I (2 puertas) (1968 - 1975)

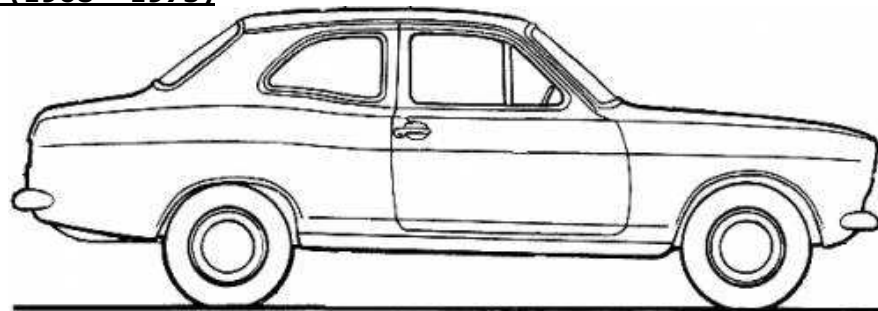

Ford Escort Mark II (2 puertas) (1975 - 1980)



Ford Sierra (3 puertas) (1983 - 1991)

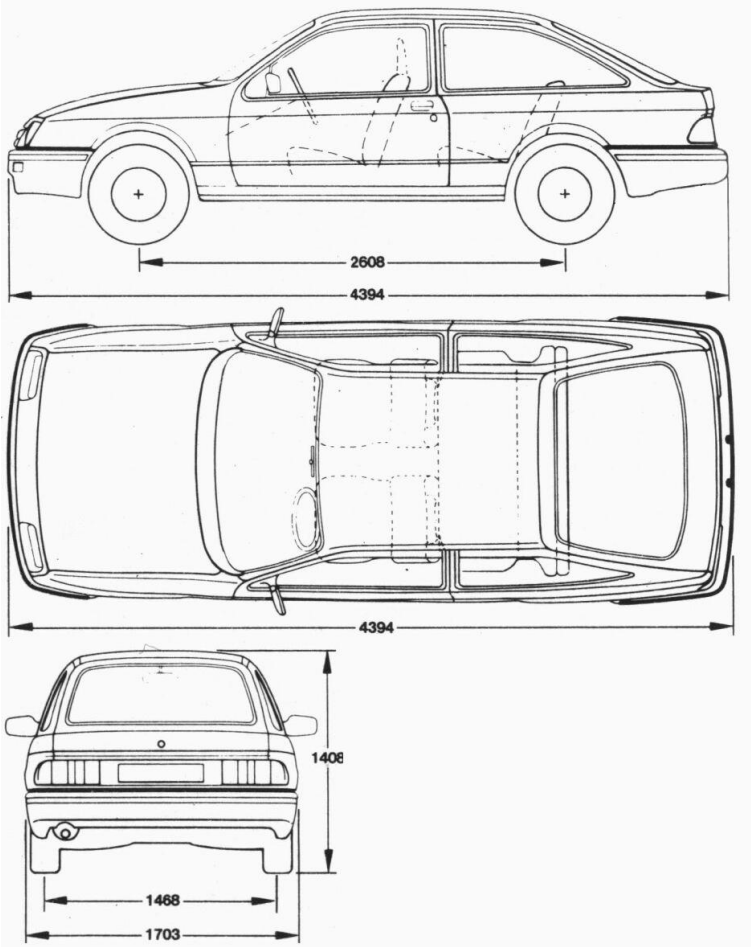

Lancia Beta Coupé (1972 - 1984)

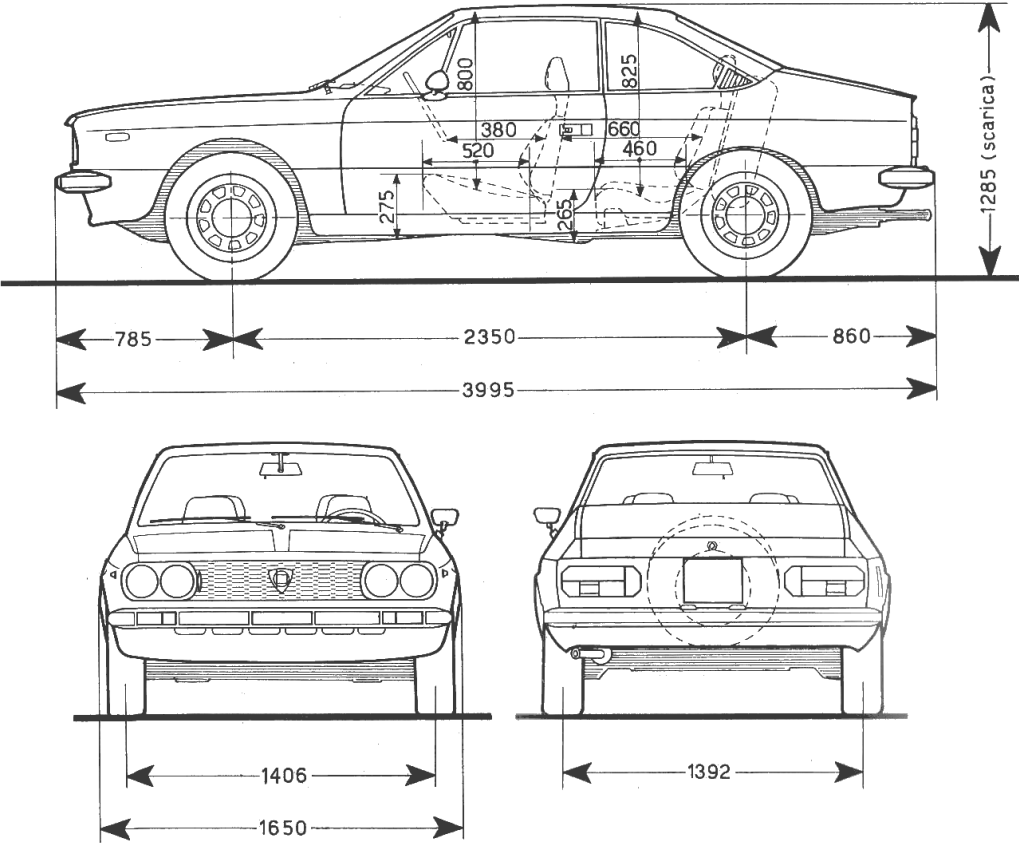

Lancia Beta HPE (1972 - 1984)

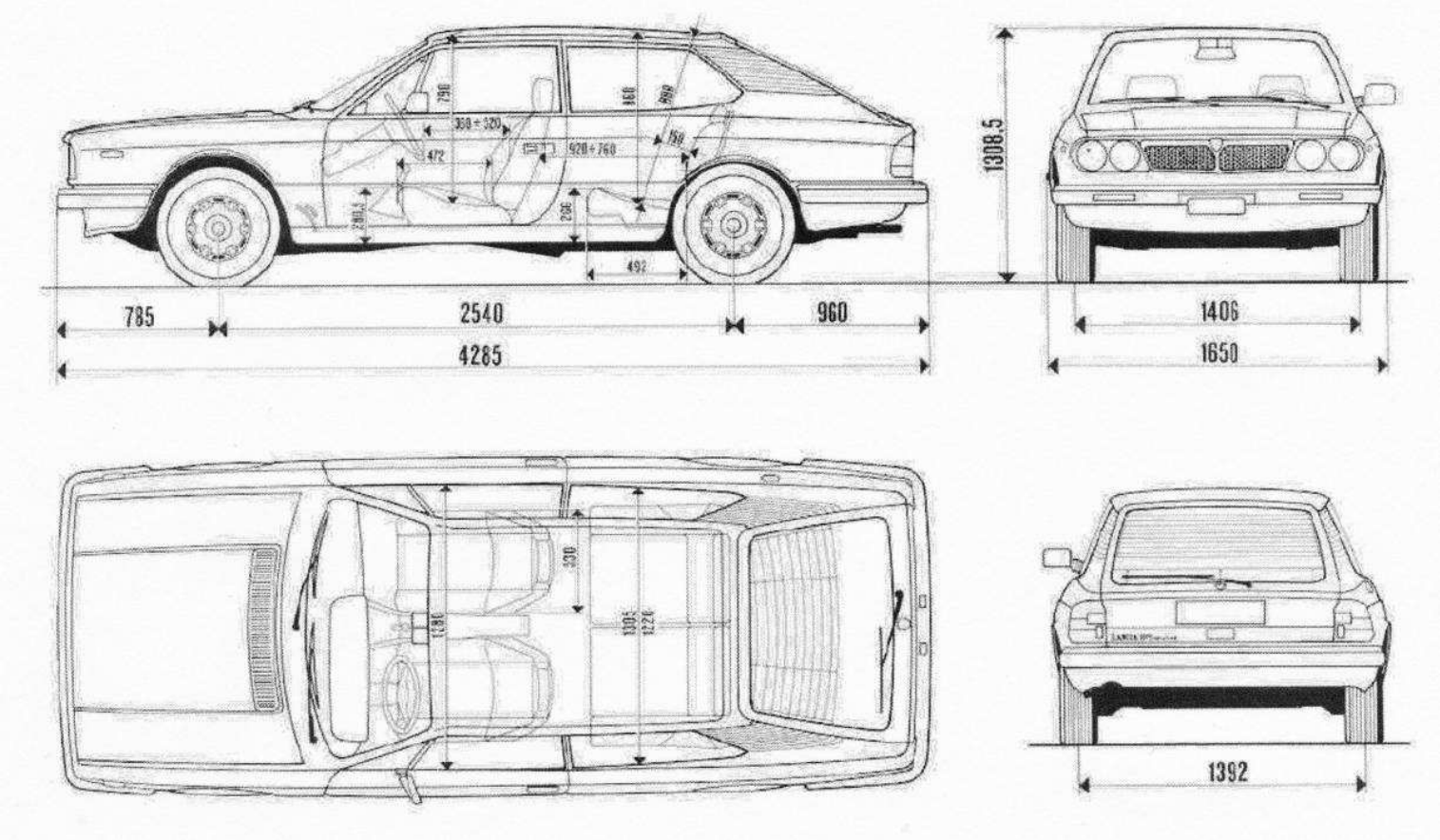

Lancia Beta Montecarlo (1975 - 1978)

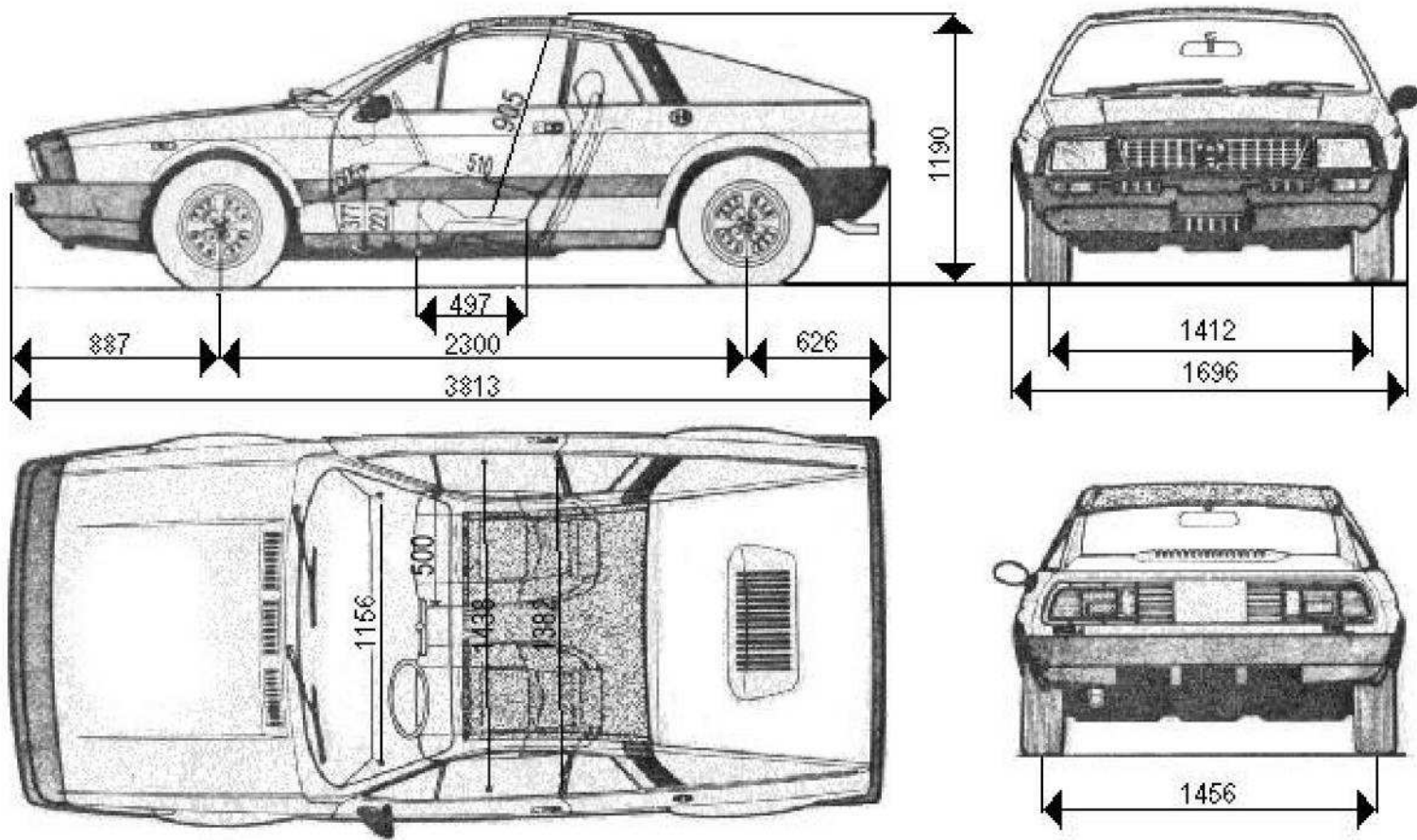

Lancia Fulvia Coupé (1965 - 1976)

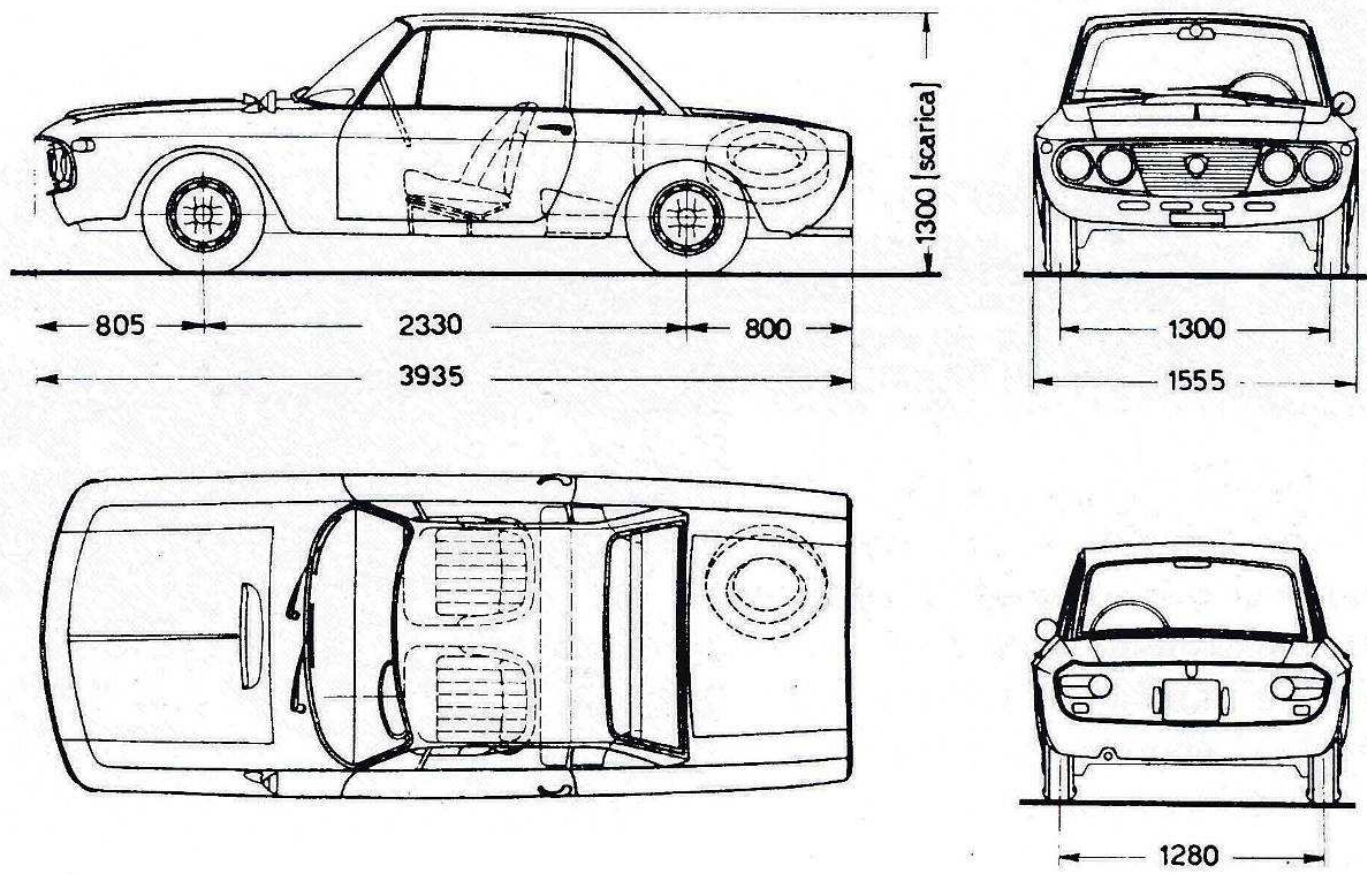

Lancia Fulvia Sport (1965 - 1976)

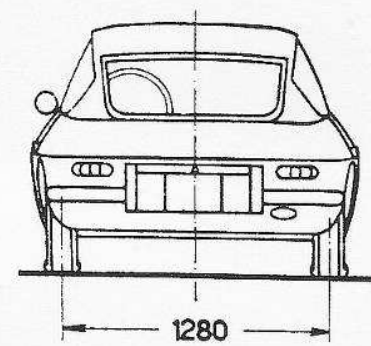
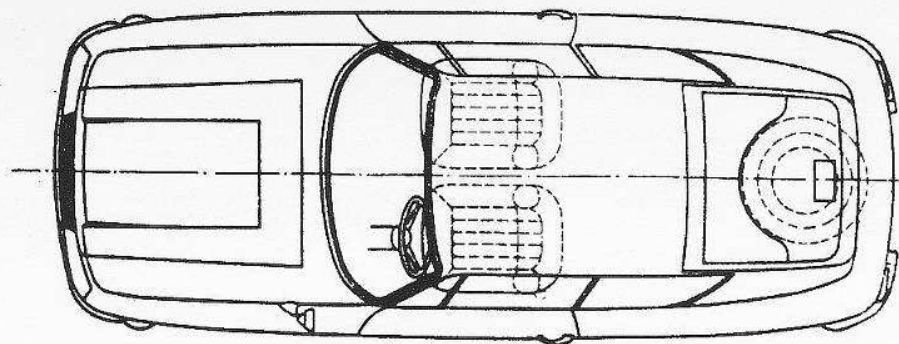
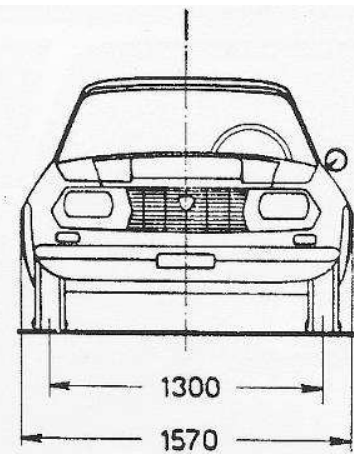
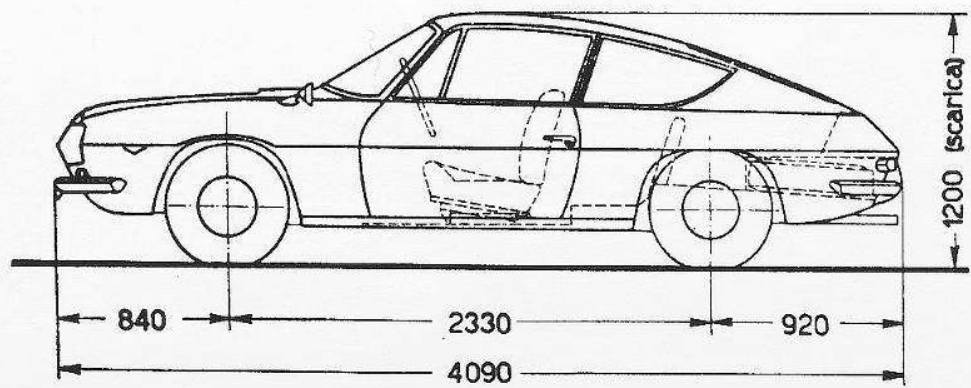

Lancia Montecarlo (1980 - 1981)

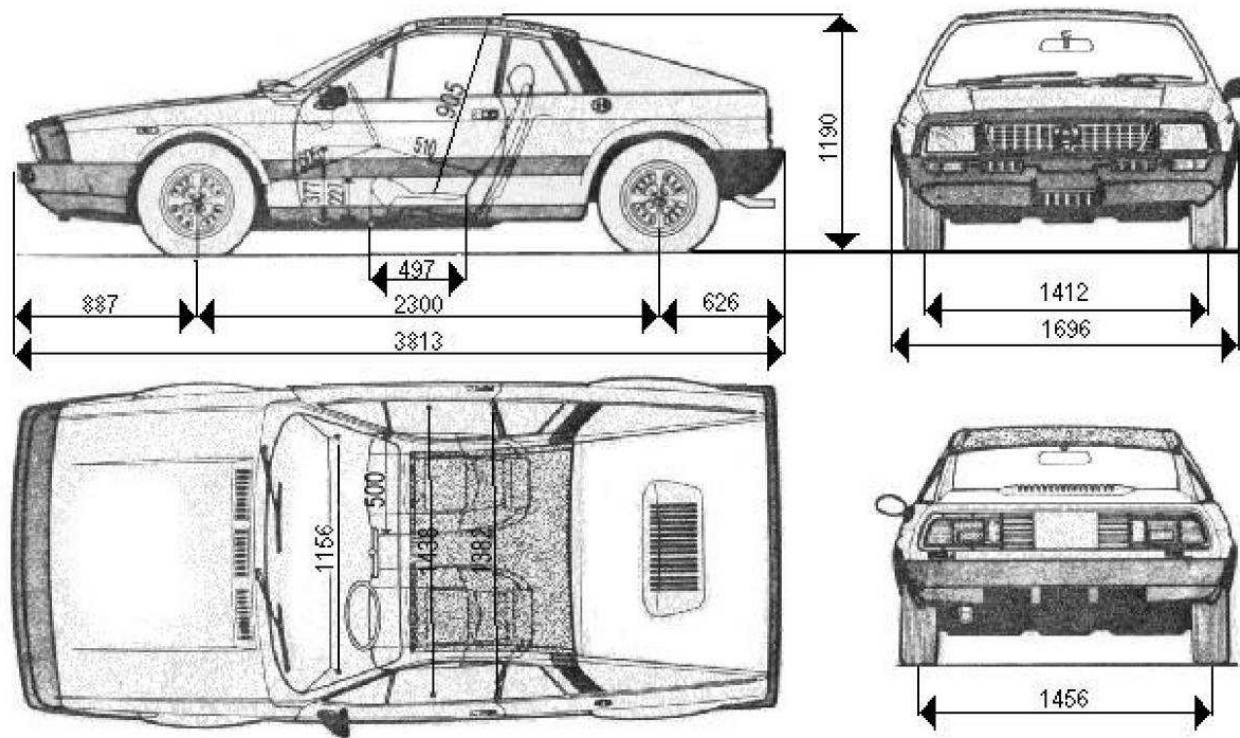

Mercedes-Benz 190 W201 (4 cilindros) (1982 - 1993)

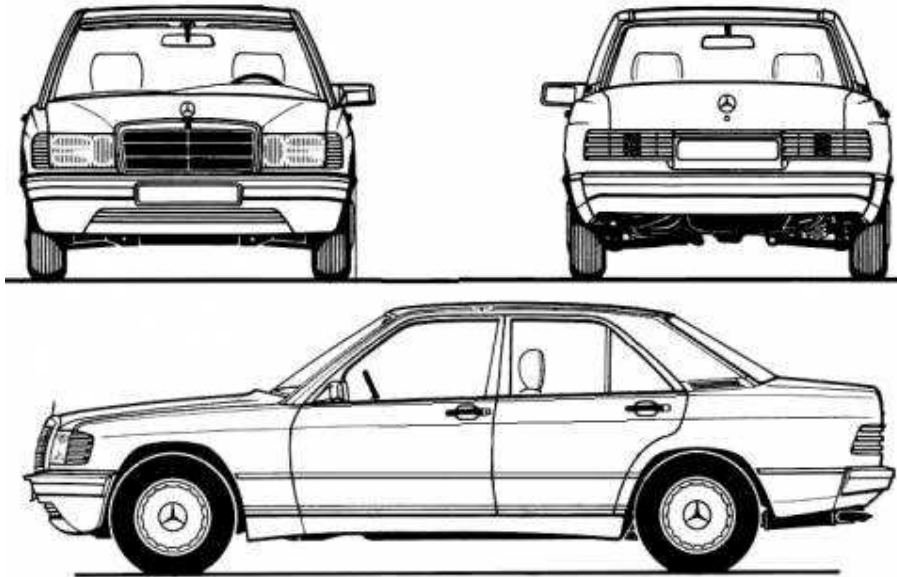

MG B (1962 - 1980)

MG B GT (4 cilindros) (1965 - 1980)

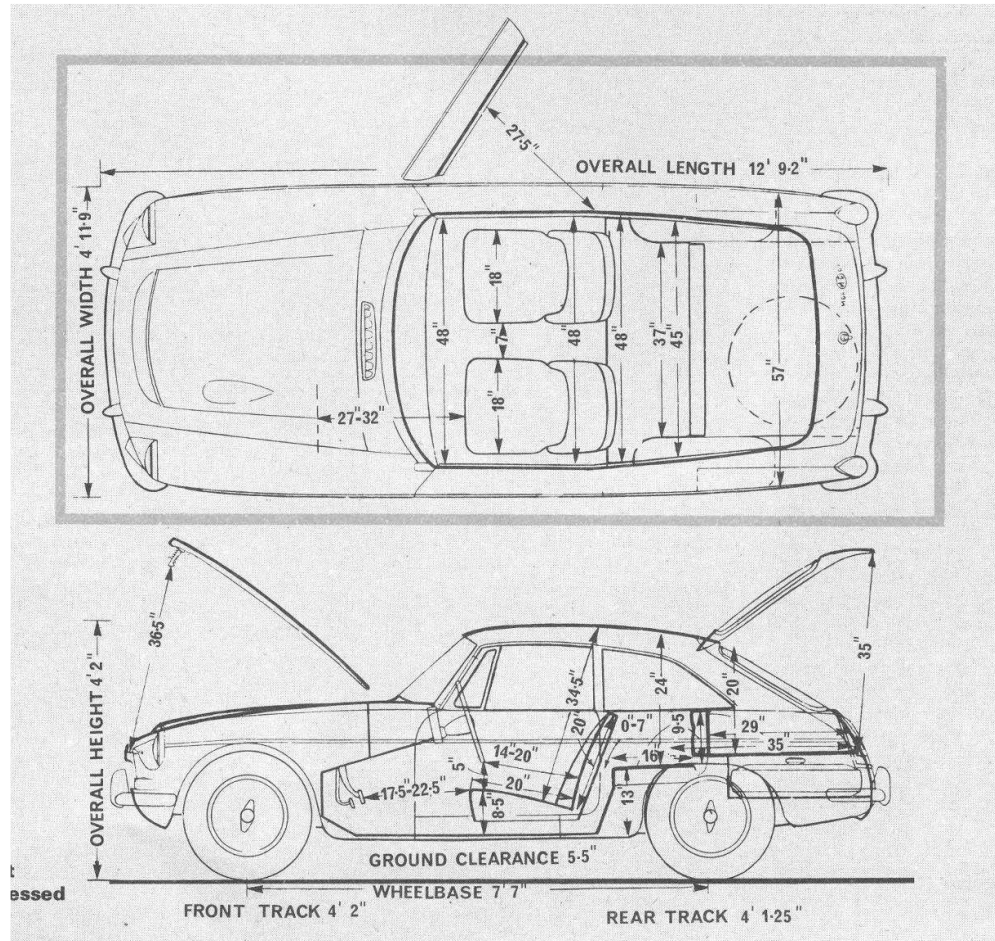

Peugeot 205 (3 puertas) (1983 - 1998)

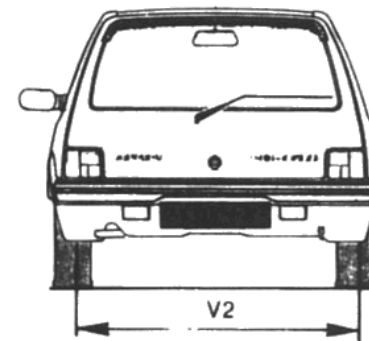
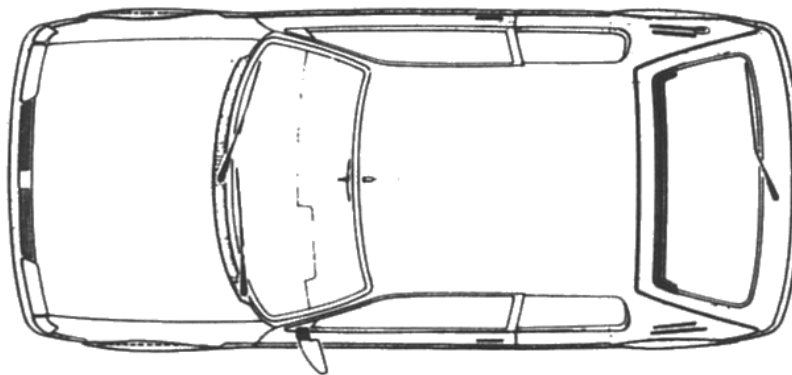
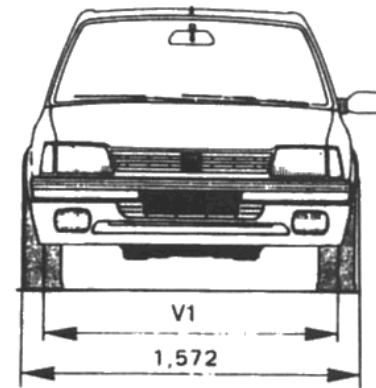
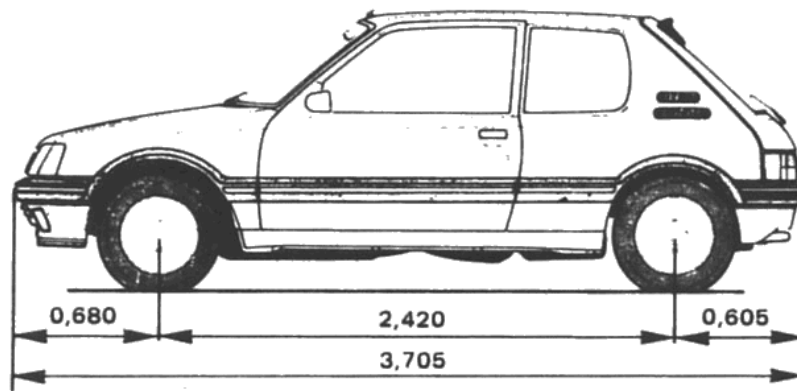

Peugeot 504 Coupé (4 cilindros) (1969 - 1983)

DIMENSIONS - DIMENSIONI

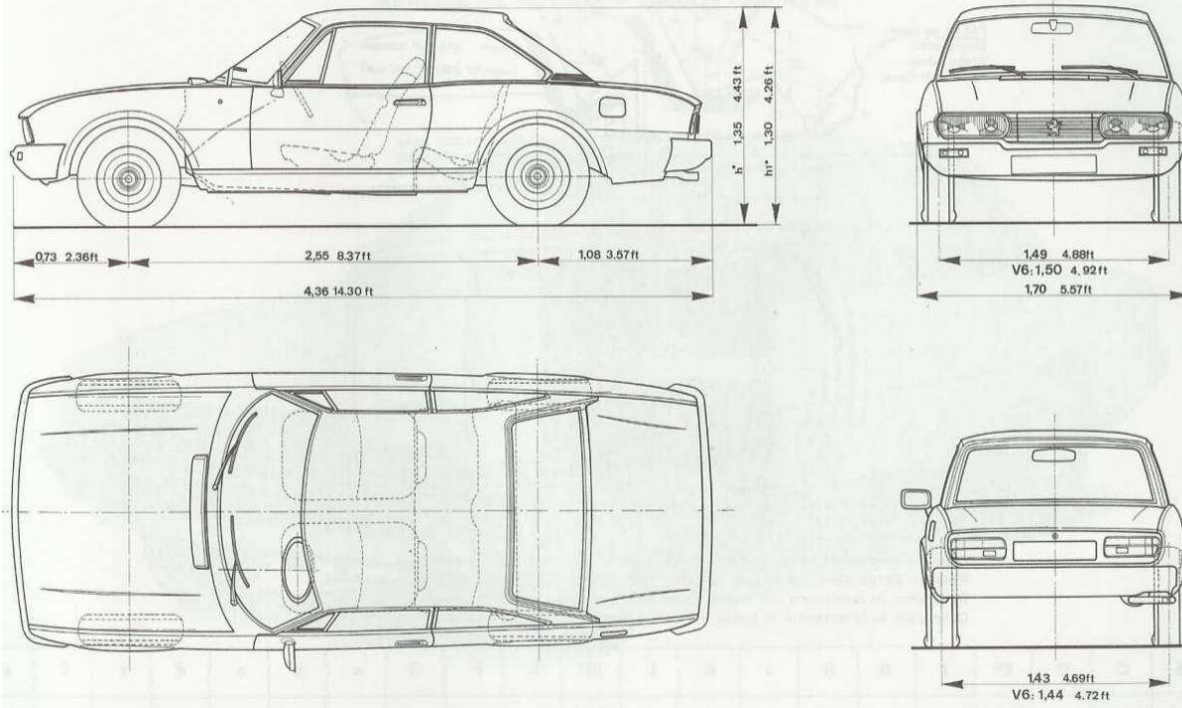

Porsche 912 (1965 - 1969)

Porsche 912E (1976 - 1976)

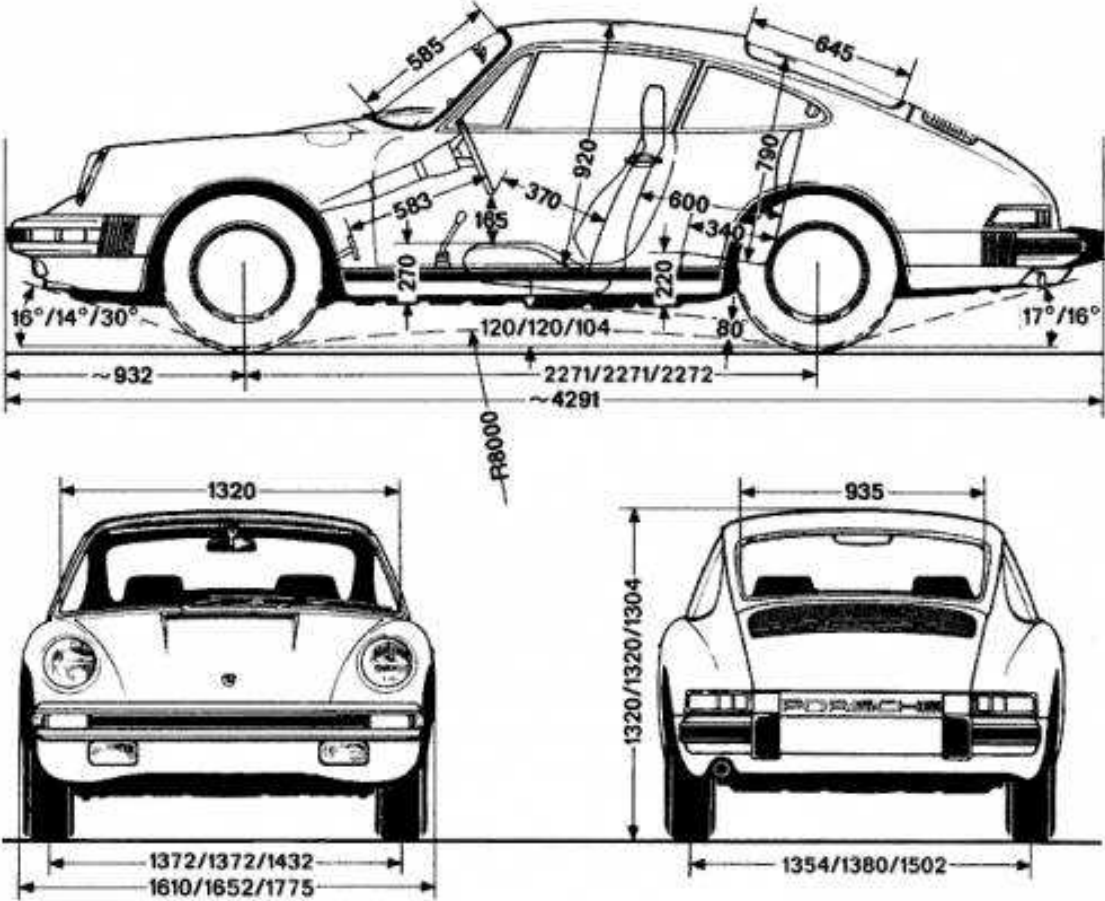

Porsche 924 (1976 - 1985)

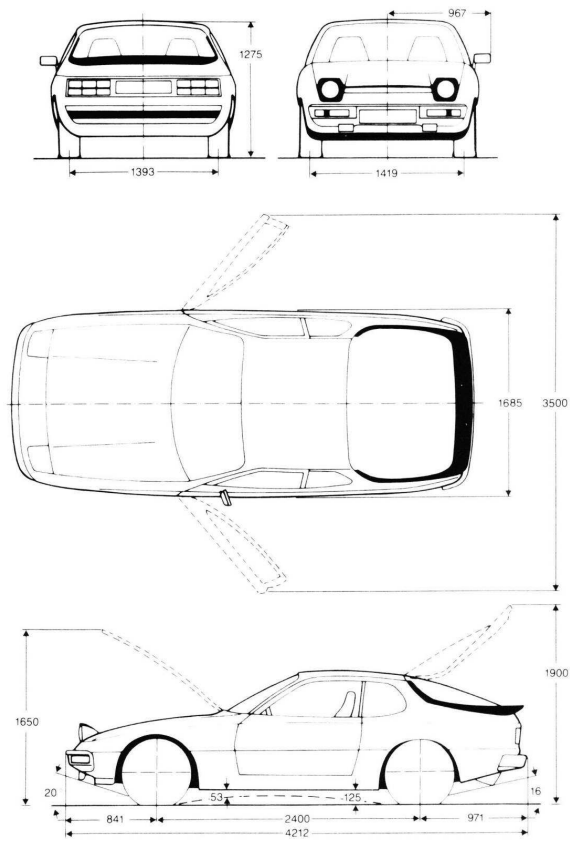

Renault 5 primera serie (3 puertas) (1972 - 1984)

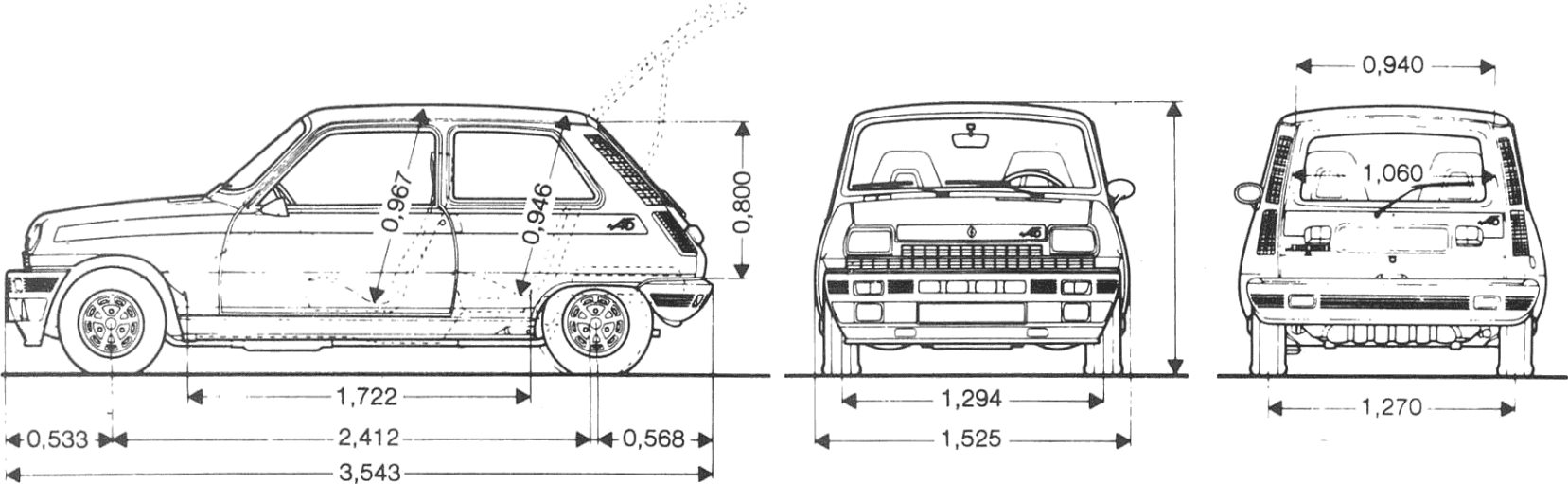

Renault Fuego (1980 - 1992)

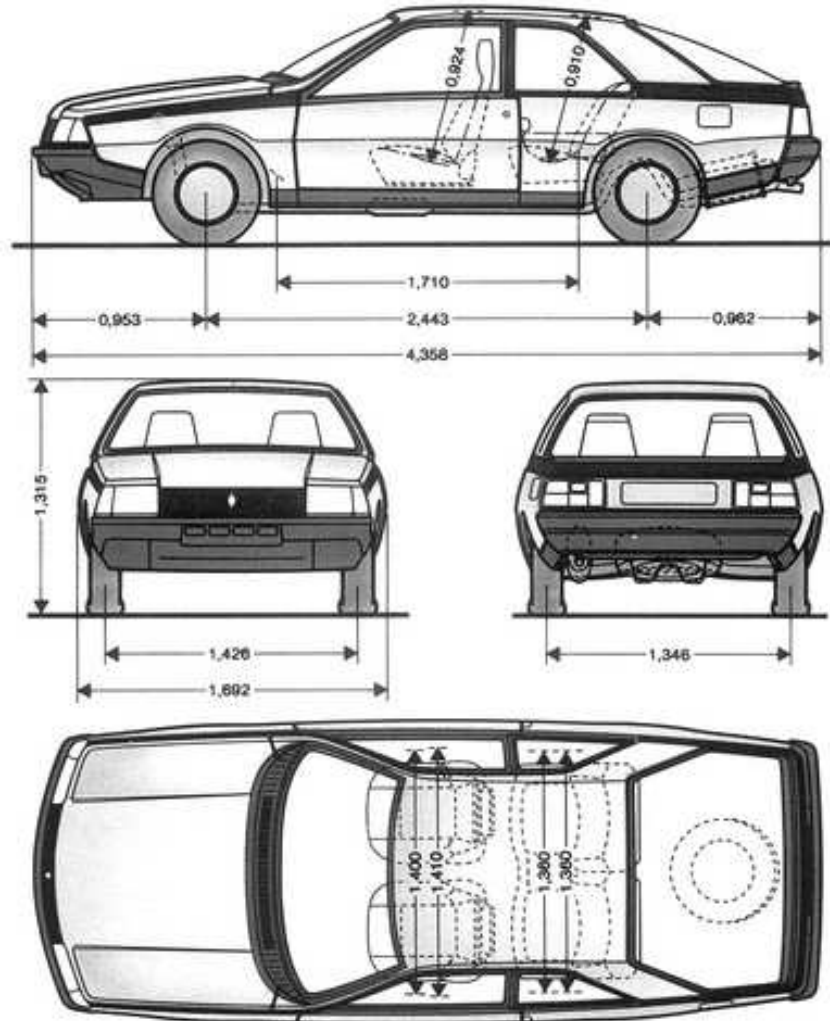

Toyota Célica A20/35 (1970 - 1977)

Toyota Célica A40 (1978 - 1981)

Volkswagen Golf MkI (3 puertas) (1974 - 1984)

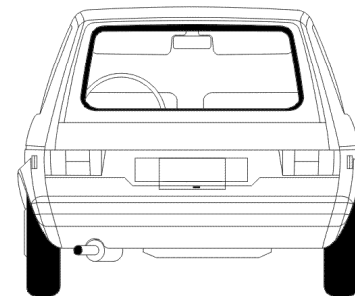
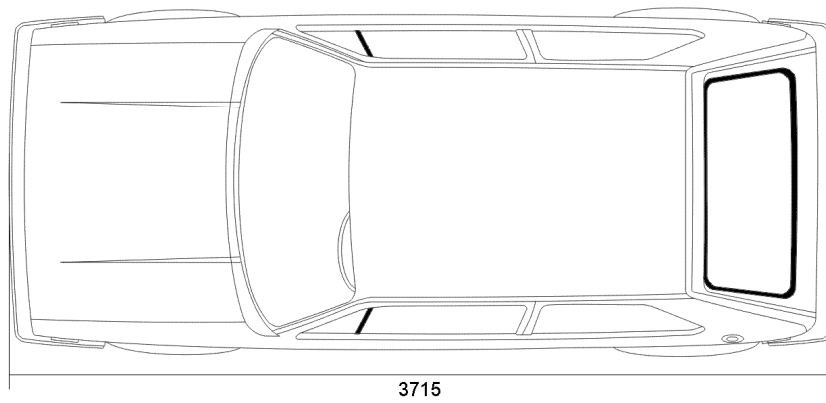
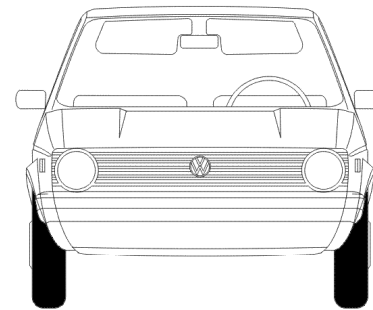
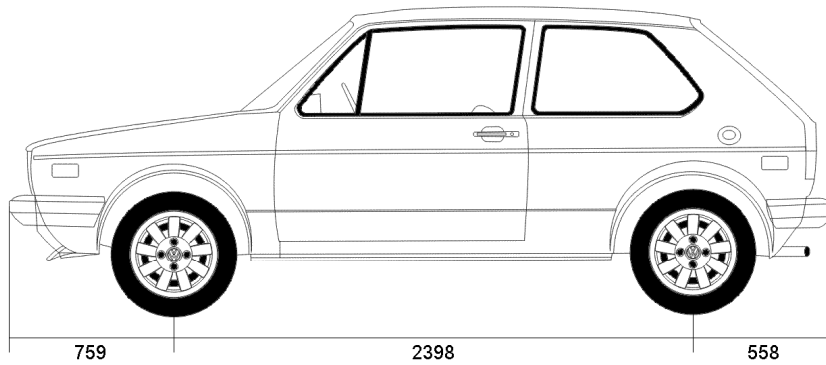

Volkswagen Golf MkII (3 puertas) (1983 - 1992)

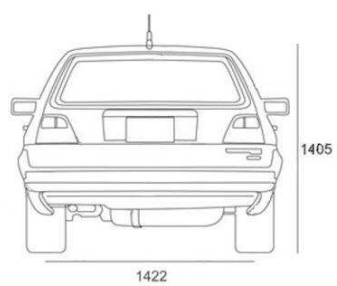
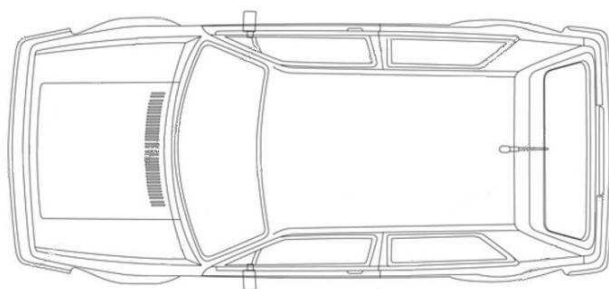
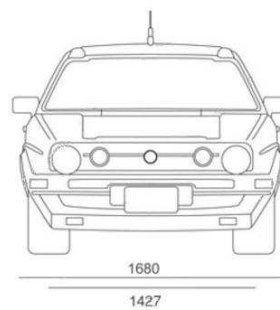
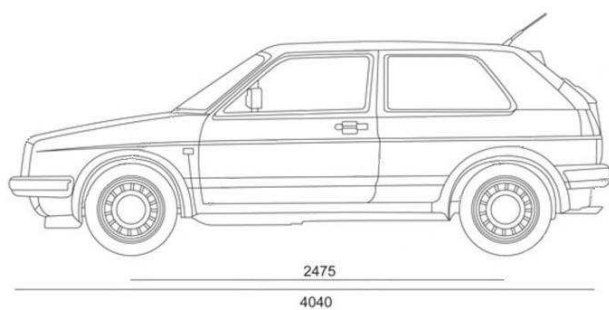

Volkswagen Passat B1 (2 ó 3 puertas) (1973 - 1988)

Volkswagen Scirocco MkI (1974 - 1982)

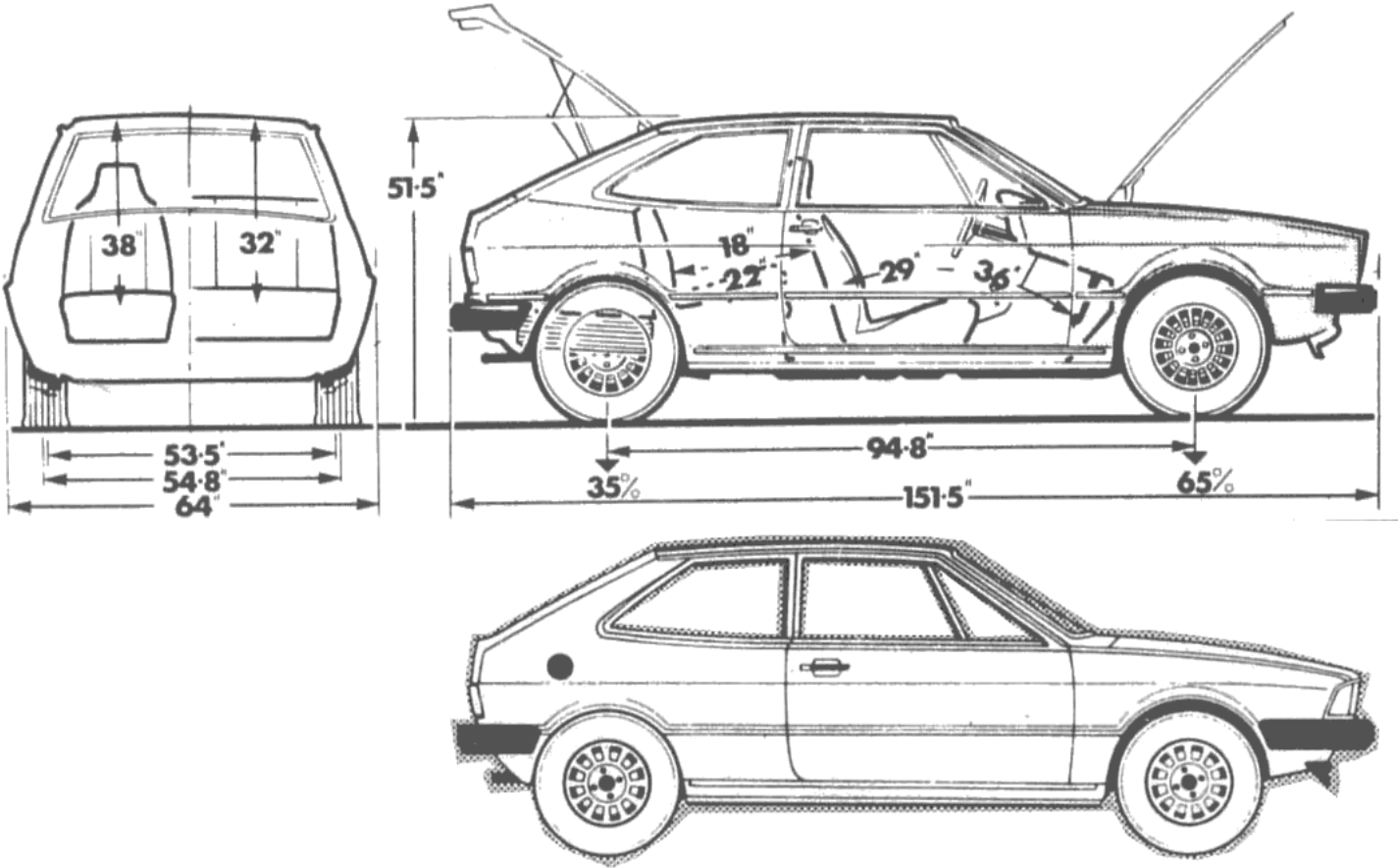

Volkswagen Scirocco MkII (1982 - 1992)

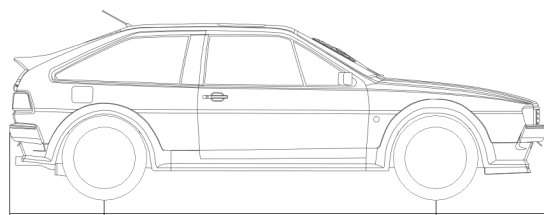
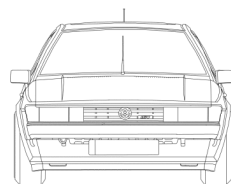
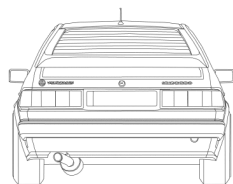
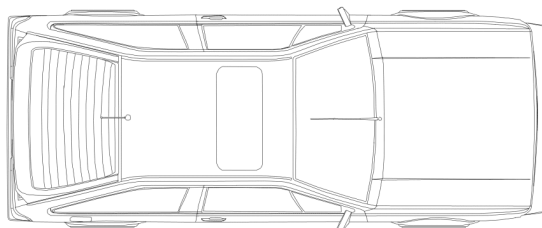

682

2400

829

Volkswagen-Porsche 914 (4 cilindros) (1969 - 1976)

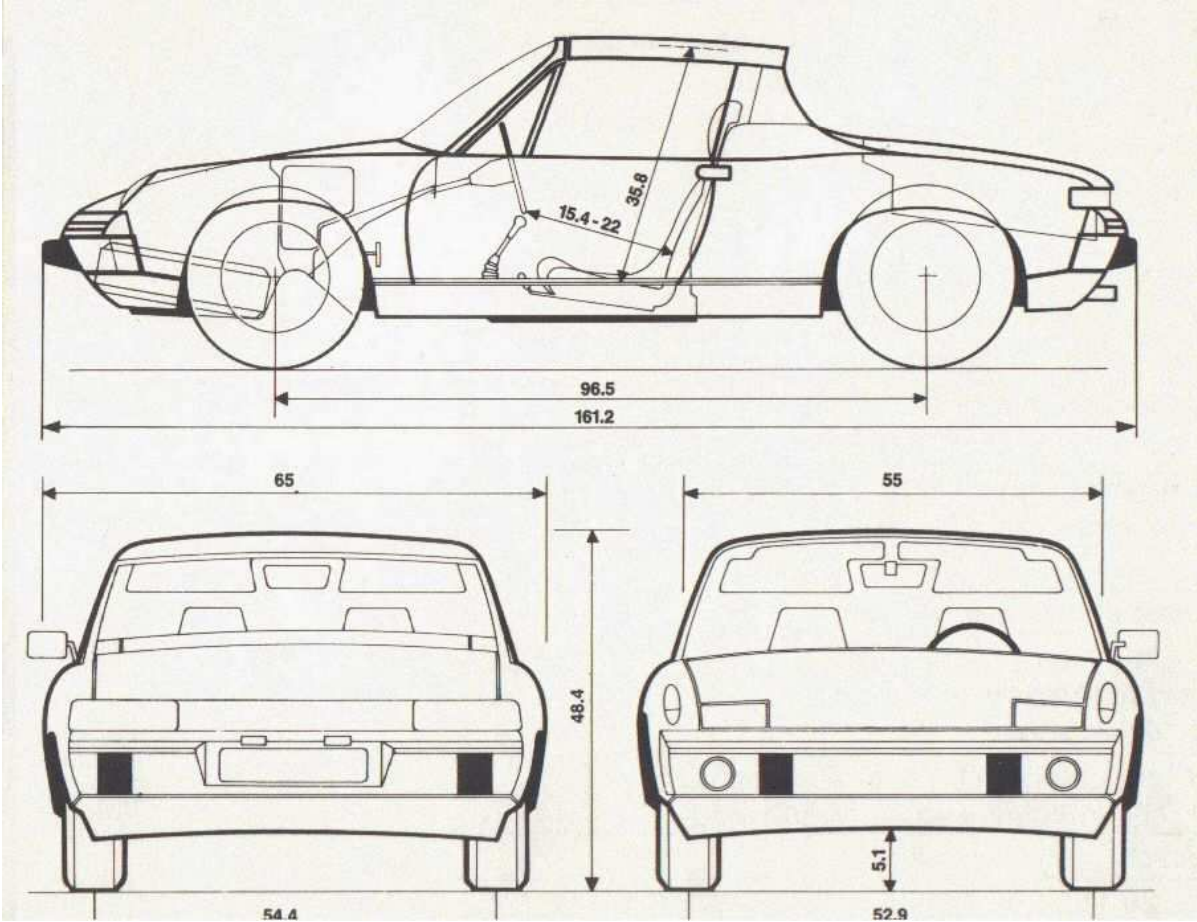

Volvo 242 (1974 - 1984)

